



Parts Manual - 26479
Revision D

Fill in appropriate fields that apply to this machine

Machine S/N: _____

1st Hose S/N: _____

2nd Hose S/N: _____

1st Pump S/N: _____

2nd Pump S/N: _____

Engine S/N: _____

Compressor S/N: _____

Gear Box S/N (Patcher): _____

Blower S/N (Magnum): _____



**EZ1500 Series II Double Pumper Melter - Electric Hose
PN 46500EB**



**EZ1500 Series II Double Pumper Melter - Standard Hose
PN 46500SB**

Table of Contents

1.0 About This Manual	1-1
1.1 How to use this manual:	1-1
2.0 Safety Precautions	2-1
2.1 General Safety.....	2-1
2.2 Personal Safety	2-1
2.3 Equipment or Operational Safety	2-1
2.4 Safety Symbols and Notices	2-2
3.0 Limited Warranty.....	3-1
3.1 Warranty Claim Instructions.....	3-2
4.0 Machine Specifications	4-1
5.0 Operating Instructions	5-1
5.1 Preparing the Machine for Start Up.....	5-1
5.2 Machine Start Up for Electric Hose	5-3
5.3 Altitude Compensation System.....	5-5
5.4 About the Heated Hose, Wand, Valve, and Tip Guard	5-5
5.5 Electric Hose Care and Cautions.....	5-6
5.6 Storing the Electric Hose for Transport	5-6
5.7 Machine Start Up for Standard Hose	5-7
5.8 Loading Material into the Sealant Tank.....	5-8
5.8.1 Material Tank Depth Chart.....	5-9
5.9 Dispensing the Material	5-10
5.10 Shutting Down and Cleaning Out the Machine.....	5-11
5.11 Storing the Machine.....	5-13
6.0 Maintenance Instructions	6-1
6.1 Engine	6-1
6.2 Hydraulic System.....	6-1
6.3 Heat Transfer Oil	6-1
6.4 Wheel Bearing	6-1
6.5 Material Sensor Tube	6-1
6.6 Cleaning Material Tank and Sensor Area	6-1
6.7 Lug Nuts	6-1
6.8 Brakes	6-2
6.9 Tongue Jack.....	6-2
6.10 Temperature control Calibration.....	6-2

Table of Contents

6.11 Burner Flame Retainer	6-2
6.12 Maintenance Chart	6-2
6.13 Service Instructions	6-3
6.14 General Maintenance Parts	6-3
6.15 Recommended Spare Parts	6-4
6.16 Recommended Fluids and Lubricants	6-4
6.17 Applicable Brands of Heat Transfer Oil	6-5
6.18 Typical Heat Transfer Oil Specifications	6-5
6.19 Material Pump Replacement	6-6
7.0 How to Use a Multimeter	7-1
7.1 Checking DC Voltage with a Multimeter	7-1
7.2 Checking AC Voltage with Multimeter	7-1
7.3 Checking Resistance (Ohms)	7-1
7.4 Checking Amperage	7-2
8.0 Burner Troubleshooting	8-1
8.1 Sealant is Heating Slowly	8-11
8.2 Mixer Troubleshooting	8-12
8.2.1 Symptom: Mixer Does Not Rotate	8-12
8.2.2 Mixer Hydraulic Troubleshooting	8-18
8.3 Hose Troubleshooting	8-21
8.3.1 Symptom: Hose Does Not Heat	8-21
8.3.2 Symptom: Trigger is not working	8-26
8.3.3 RTD Sensor Ohms vs. Temperature	8-27
8.4 Pump Troubleshooting	8-29
8.4.1 Symptom: Material Does Not Dispense When the P.S. Pump is Activated	8-29
8.4.2 Symptom: Material Does Not Dispense When the D.S. Pump is Activated	8-34
9.0 About the Illustrated Parts List	9-41
9.1 Ordering Crafco Parts	9-41
9.2 EZ1500 Series II Double Pumper Parts List	9-42
9.3 Machine Options	9-48
9.4 Tank Assembly	9-51
9.5 Plumbing Assembly	9-52
9.6 Control Box Assembly – Electric Hose	9-54
9.7 Control Box Assembly, D.S. –Electric Hose	9-58

Table of Contents

9.8 Control Box Assembly – Standard Hose	9-60
9.9 Control Box Assembly, D.S. – Standard Hose	9-64
9.10 Engine Assembly – 46500SB	9-66
9.11 Engine Assembly – 46500EB	9-67
9.12 Hydraulic Control Valve Assembly – Passenger Side	9-68
9.13 Hydraulic Control Valve – Drivers Side	9-69
9.14 Burner Assembly	9-70
9.15 Material Pump Assembly – Passenger Side	9-72
9.16 Material Pump Assembly – Drivers Side	9-73
9.17 Hydraulic Diagram	9-74
9.18 Electrical Schematic – Electric Hose.....	9-82
9.19 Electrical Schematic – Standard Hose	9-84
9.20 Hot Air Lance.....	9-88
10.0 Tools and Accessories	10-1

List of Figures

Fig. 5.1 Hydraulic Fluid Level and Temp. Gauge	5-2
Fig. 5.2 Heat Transfer Oil Dipstick	5-2
Fig. 6.1 Lug bolt Tightening Sequence.....	6-2
Fig. 6.2 Flame Retainer	6-2
Fig. 6.3 Temperature Control Calibration	6-2
Fig. 6.4 Material Pump Replacement.....	6-7
Fig. 7.1 Standard Multimeter.....	7-2
Fig. 7.2 Clamp – On Amp Meter/Multimeter	7-3
Fig. 8.1 Diesel Burner Schematic.....	8-6
Fig. 8.2 Diesel Burner Electrode Adjustment.....	8-10
Fig. 8.3 Diesel Burner Air Settings	8-10
Fig. 8.4 Checking Din Plug Voltage.....	8-16
Fig. 8.5 Mixer Circuit.....	8-17
Fig. 8.6 P.S. Hydraulic Valve Pressure Setting	8-19
Fig. 8.7 P.S. Hydraulic Valve Din Plug Layout	8-20
Fig. 8.8 Junction Box Voltage Testing.....	8-23
Fig. 8.9 Hose Circuit Schematic.....	8-24
Fig. 8.10 Junction Box Wiring	8-25
Fig. 8.11 P.S. Pump Circuit Schematic	8-33
Fig. 8.12 D.S. Pump Circuit Schematic	8-38
Fig. 8.13 D.S. Hydraulic Valve Din Plug Layout	8-39
Fig. 8.14 D.S. Hydraulic Valve Pressure Setting	8-39
Fig. 9.1 EZ1500 Series II Double Pumper Melter	9-42
Fig. 9.2 EZ1500 Series II Double Pumper Melter	9-44
Fig. 9.3 EZ1500 Series II Double Pumper Melter	9-46
Fig. 9.4 EZ1500 Series II Melter Options	9-48
Fig. 9.5 Tank Detail.....	9-51
Fig. 9.6 Plumbing.....	9-52
Fig. 9.7 Control Box Assembly 46500EB	9-54
Fig. 9.8 Control Box Assembly: 46500EB	9-56
Fig. 9.9 Control Box Assembly – D.S. Electric	9-58

List of Figures

Fig. 9.10 Control Box Assembly: 46500SB.....	9-60
Fig. 9.11 Control Box Assembly: 46500SB.....	9-62
Fig. 9.12 Control Box Assembly, D.S. – Standard Hose.....	9-64
Fig. 9.13 Engine Assembly - 46500SB.....	9-66
Fig. 9.14 Engine Assembly - 46500EB.....	9-67
Fig. 9.15 Hydraulic Control Valve P.S.....	9-68
Fig. 9.16 Hydraulic Control Valve, D.S.....	9-69
Fig. 9.17 Diesel Burner.....	9-70
Fig. 9.18 Material Pump Assembly, P.S.....	9-72
Fig. 9.19 Material Pump Assembly, D.S.....	9-73
Fig. 9.20 Hydraulic Diagram.....	9-74
Fig. 9.21 Hydraulic Diagram.....	9-76
Fig. 9.22 Hydraulic Diagram.....	9-78
Fig. 9.23 Hydraulic Diagram.....	9-80
Fig. 9.24 Electrical Schematic 46500EB.....	9-82
Fig. 9.25 Electric Schematic – 46500SB.....	9-84
Fig. 9.26 Diesel Fuel Line Schematic.....	9-86
Fig. 9.27 Hot Air Lance (Option).....	9-88

List of Tables

Table 2-1 Safety Symbols and Notices	2-2
Table 2-2 Safety Symbols and Notices (continued).....	2-3
Table 4-1 Machine Specifications	4-1
Table 5-1 Preparing the Machine for Start Up.....	5-1
Table 5-2 Starting the Burner for Electric Hose	5-3
Table 5-3 Electric Hose Care	5-6
Table 5-4 Hose for Transport Instructions.....	5-6
Table 5-5 Starting the Burner for Standard Hose	5-7
Table 5-6 Loading Material into the Sealant Tank	5-8
Table 5-7 Material Tank Depth Chart.....	5-9
Table 5-8 Dispensing the Material – Electric Hose.....	5-10
Table 5-9 Dispensing the Material – Standard hose.....	5-11
Table 5-10 Shutting Down with an Electric Hose.....	5-12
Table 5-11 Shutting Down with a Standard Hose.....	5-12
Table 6-1 Maintenance Chart.....	6-2
Table 6-2 Service Instructions.....	6-3
Table 6-3 General Maintenance Parts	6-3
Table 6-4 Recommended Spare Parts.....	6-4
Table 6-5 Recommended Fluids and Lubricants	6-4
Table 6-6 Applicable Brand of Heat Transfer Oil.....	6-5
Table 6-7 Material Pump Replacement.....	6-6
Table 8-1 Basic Visual Burner Troubleshooting	8-1
Table 8-2 Basic Visual Burner Troubleshooting (continued).....	8-2
Table 8-3 Burner Electrical Troubleshooting	8-2
Table 8-4 Burner Electrical Trouble shooting (continued).....	8-3
Table 8-5 Burner Electrical Trouble shooting (continued).....	8-4
Table 8-6 Burner Electrical Trouble shooting (continued).....	8-5
Table 8-7 Smoke Coming Out of the Exhaust Stack	8-7
Table 8-8 Burner Lights but Shuts Down After 15 Seconds	8-7
Table 8-9 Testing the DC Controller.....	8-8
Table 8-10 Burner Fuel Solenoid Test	8-8

List of Tables

Table 8-11 Burner Ignition Coil Test.....	8-9
Table 8-12 Bleeding the Diesel Burner.....	8-9
Table 8-13 Sealant is Heating Slowly.....	8-11
Table 8-14 Basic Visual Mixer Troubleshooting.....	8-12
Table 8-15 Mixer Electrical Troubleshooting	8-13
Table 8-16 Mixer Electrical Troubleshooting (continued).....	8-14
Table 8-17 Mixer Electrical Troubleshooting (continued).....	8-15
Table 8-18 Mixer Hydraulic Troubleshooting	8-18
Table 8-19 Basic Visual Hose Troubleshooting.....	8-21
Table 8-20 Hose Electrical Troubleshooting.....	8-21
Table 8-21 Hose Electrical Troubleshooting (continued)	8-22
Table 8-22 Hose Electrical Troubleshooting (continued)	8-23
Table 8-23 Trigger is Not Working.....	8-26
Table 8-24 RTD Sensor Ohms vs. Temperature	8-27
Table 8-25 RTD Sensor Ohms vs. Temperature (continued).....	8-28
Table 8-26 Basic Visual P.S. Pump Troubleshooting	8-29
Table 8-27 P.S. Pump Electrical Troubleshooting	8-30
Table 8-28 P.S. Pump Electrical Troubleshooting (continued).....	8-31
Table 8-29 P.S. Pump Electrical Troubleshooting (continued).....	8-32
Table 8-30 P.S. Pump Electrical Troubleshooting (continued).....	8-33
Table 8-31 Basic Visual D.S. Pump Troubleshooting	8-34
Table 8-32 D.S. Pump Electrical Troubleshooting	8-35
Table 8-33 D.S. Pump Electrical Troubleshooting (continued)	8-36
Table 8-34 D.S. Pump Electrical Troubleshooting (continued)	8-37
Table 8-35 Pump Hydraulic Troubleshooting	8-40

Chapter 1 Introduction

1.0 About This Manual

This manual is supplied with each new CrafcO EZ Series II 1500 Double Pumper Diesel Melter. The manual assists your machine operators in the proper use of the melter applicator and provides information about the machine's mechanical functions.

Your CrafcO EZ Series II 1500 Double Pumper Diesel Melter is specially made to give excellent service and save maintenance expense. However, as with all specially engineered equipment, you get best results at minimum cost if you:

Operate your machine as instructed in this manual.

Maintain your machine regularly as stated in this manual.

1.1 How to use this manual:

This manual is formatted to start each new chapter on the right page. There may be a blank page on the left page if the previous chapter ends on the right page.

If you are viewing this in a digital format (PDF) the following features are available:

1. The Table of Contents, List of Tables, and List of Figures are all hyperlinks, when left mouse clicked on section, table, or figure you will be sent to that page.
2. The blue highlighted text throughout the manual is a hyperlink, when left mouse clicked you will be sent to that page, table, or figure.
3. The panel to the left in the PDF is a bookmarks panel, if you left mouse click on any section/heading in the bookmarks panel you will be sent to that page.
4. There is an attachments icon (paper clip) to the left of the bookmarks, this is where you will find full size prints of the control box, electrical, and hydraulic schematics

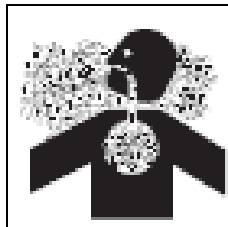

WARNING

California Proposition 65 Warning

Engine exhaust and some of its constituents are known to the State of California to cause cancer, birth defects, and other reproductive harm. Always use care to avoid breathing engine exhaust. Failure to comply could result in death or serious injury.

Chapter 2 Safety

2.0 Safety Precautions

For more in-depth safety information, please see Safety Manual (PN 26221) which comes with the machine. Or contact your nearest authorized Crafco Distributor at crafco.com/Distributors.

2.1 General Safety

- Crafco, Inc. assumes no liability for an accident or injury incurred through improper use of the machine.
- Read this manual thoroughly before operating the machine.
- Obey all CAUTION and WARNING signs posted on the machine.
- Make sure an operator fully knows how to operate the machine before using the machine.

2.2 Personal Safety

- The high operating temperatures of this machine and the sealant it contains requires that protective clothing, gloves, hard-soled shoes, and safety glasses or a face shield be worn at all times by operators of the machine.
- Prevent water from going into any part of the machine. If there is indication of water in the heat transfer oil system, warm heating oil to 250-300°F for 2 to 3 hours.
- Bodily contact with hot sealant or heat transfer oil can cause severe burns.
- If the mixer is not stopped before adding solid material, hot material can get on an operator's body and cause severe burns.
- Keep hands, feet, and clothing away from all moving parts.

2.3 Equipment or Operational Safety





- Do not operate the machine in buildings or work areas that do not have sufficient airflow.
- Shut-down the burner and the engine before refilling the fuel tank.
- Make sure mixer stops before adding solid material to the sealant tank. Lift the lid, place the material on the lid and close the lid. The mixer should restart automatically.
- Always keep a correctly maintained fire extinguisher near the machine and know how to use it.
- DO NOT heat transfer oil to a temperature of more than 525°F.
- DO NOT put too much heat transfer oil in the reservoir. The expansion of oil while it heats up can cause overflow. With the machine on level ground, check the oil each day before starting the burner. Add oil to the top mark on the dipstick if required (at 70°F). Use only recommended heat transfer oil. Change the oil after 500 hours of machine operation, or one year, whichever comes first.
- Follow the operating instructions for starting and shutting down the burner. Instructions are mounted on the control box on the machine.
- Calibrate the temperature control operation after each 50 hours of machine operation. Refer to section [6.9 Temperature control Calibration](#).
- Replace any hoses which show signs of wear, fraying or splitting.
- Make sure all fittings and joints are tight and do not leak each time the machine is used.
- Do not leave the machine unattended while the burner is lit.
- Tighten all bolts and screws every 100 hours of machine operation.

Chapter 2 Safety

2.4 Safety Symbols and Notices





Important safety symbols and notices are marked on the machine and in this manual. Failure to comply could result in equipment damage, operational malfunction, serious injury, or death. Please read and comply with all symbols and notices. The table below includes the most commonly used symbols and notices.

Table 2-1 Safety Symbols and Notices

Symbol	Item	Remarks
WARNING	Warning	Refers to possible bodily injury or death.
CAUTION	Caution	Refers to possible equipment damage or operational malfunction.
	Severe Burn Hazard	Hot material can cause severe burns.
	Protective Shoes	Wear hard-soled work shoes.
	Protective Gloves	Wear heat resistant gloves.
	Protective Face or Eye Wear	Wear face shield or safety glasses.
	Body Crush Hazard	Do not stand between trailer and hitch when hooking melter to truck.

Chapter 2 Safety

Table 2-2 Safety Symbols and Notices (continued)

Symbol	Item	Remark
	Crush Hazard	Keep feet and legs clear.
	Pinch Hazard	Keep hands and feet clear.
	Exhaust Hazard	Avoid breathing engine exhaust.
	Read Manual	Read and understand operator and safety manuals before operating machine.

Chapter 3 Warranty Information

3.0 Limited Warranty

Crafco, Inc., through Crafco or one of its affiliated distributors, will replace for the original purchaser free of charge any parts found upon examination by the factory at Chandler, Arizona, to be defective in material or workmanship. This warranty is for a period one year from in-service date, but excludes engine or components, tires, and battery as these items are subject to warranties issued by their manufactures.

Crafco, Inc. shall not be liable for parts that have been damaged by accident, alteration, abuse, improper lubrication/maintenance, normal wear, or other cause beyond our control.

The warranty provided herein extends only to the repair and/or replacement of those components on the equipment covered above and does not cover labor costs. The warranty does not extend to incidental or consequential damages incurred as a result of any defect covered by this warranty.

All transportation and labor costs incurred by the purchaser in submitting or repairing covered components must be borne by the purchaser. Crafco, Inc. specifically disavows any other representation, warranty, or liability related to the condition or use of the product

CAUTION

Use of replacement parts other than genuine Crafco parts may impair the safety or reliability of your equipment and nullifies any warranty.

Chapter 3 Warranty Information

3.1 Warranty Claim Instructions

CrafcO, Inc. warrants parts and machinery purchased through CrafcO or one of its affiliated distributors for one year from purchased or in-service date. If parts fail to function within the first year of purchase, a return authorization number (RA) must be obtained. If the part was purchased through CrafcO, Inc., please contact CrafcO returns department at [Returns@CrafcO.com](mailto>Returns@CrafcO.com) for an RA number or if purchased through a CrafcO distributor please contact your distributor. Note: if the part has a serial number associated with it, for example; a machine or electric hose or wand, this must be furnished when requesting the RA number. The customer will be emailed or faxed an RA form with all instructions to return the item to CrafcO, Inc. See example. If the part is found to be within the one year warranty period and has not been abused or modified, a credit will be issued to the customer's account or credit card. The customer may request the part be replaced instead of a credit, if desired.

Wear items are not covered under CrafcO, Inc. limited warranty. A wear item is defined as but not limited to: material pumps, sealing tips, tires, etc.

Note: All engine warranties are covered through the engine manufacture. If you need information for a distributor in your area please contact us and we will direct you to the closest engine distributor.

All parts returned are tested and evaluated. If the part has been modified in anyway without prior consent from a CrafcO, Inc. representative, warranty is void.

Please follow the instructions stated below when calling in a Warranty Claim. Failure to follow these procedures may be cause to void the warranty.

Call your local CrafcO Distributor. If you do not know who your local distributor is, call a CrafcO Customer Service Representative, (Toll Free 1-800-528-8242) for name, location and telephone number.

On contacting the distributor, be prepared to identify the serial number, model number, engine number, engine manufacturer, and the date of purchase if available.

Should the cause of the malfunction be a defective part, the Distributor will advise you of the procedure to follow for a replacement.

The warranty is valid only for parts, which have been supplied or recommended by CrafcO, Inc.

If you have any additional questions regarding warrant repairs and parts, please do not hesitate to call toll free 1-800-528-8242.

For Warranty:

CrafcO, Inc.

25527 South Arizona Avenue, Chandler, AZ
85248

Phone: (480) 655-8333 or (800) 528-8242

Fax: (480) 655-1712

For all other inquires:

CrafcO, Inc.

420 North Roosevelt Avenue, Chandler, AZ
85226

Phone: (602) 276-0406 or (800) 528-8242

Fax: (480) 961-0513

CustomerService@crafcO.com

Chapter 4 Machine Specifications

4.0 Machine Specifications

Table 4-1 Machine Specifications

Specification	PN 46500EB	PN 46500SB
Vat capacity	396 gallons	
Melt Capacity	2800 lbs. per hour	
Heat transfer oil required	45.0 gallons at 70°F	
Tank construction	Double boiler type	
Tank opening size	One 14" x 18", One 16" x 24"	
Maximum heat input	420,000 BTUs	
Burner and temperature control	Diesel-forced air thermostatic control	
Engine Isuzu diesel	Three cylinder Model 3CD1TK – 35.9 BHP @ 2800 RPM	Three cylinder Model 3CE1 – 32.5 BHP @ 2800 RPM
Drive Mechanism	All hydraulic with infinite speed forward and reverse on material pump. Fixed speed agitator.	
Mixer	Full sweep mixer with 2 horizontal paddles, vertical risers	
Axle Capacity	Dual 6,000lbs.	
Tires	ST235/85R16 Load Range E	
Dry Weight Approximately	6,184lbs.	6,924lbs
Diesel tank Capacity	30 Gallons	
Hydraulic Tank Capacity	26 Gallons	

Chapter 5 Operating Instructions

5.0 Operating Instructions

The Crafcoc EZ 1500 Series II Double Pumper was developed to melt Crafcoc sealants. However, it works well with most road asphalt and federal specification crack or joint sealants.

Note: DO NOT attempt to operate the machine without using these and all other instructions.

5.1 Preparing the Machine for Start Up

Table 5-1 Preparing the Machine for Start Up

Step	Action
1	Fill the engine fuel tank with diesel fuel. Note: Use No. 1 Diesel fuel in cold weather and No. 2 Diesel fuel in warm weather
2	Check the oil level in the engine crankcase. (Refer to the manufacturer’s instruction for the engine.)
3	Check the hydraulic fluid level while at a temperature of 70°F. Add fluid if necessary. See Fig. 5.2 Hydraulic Fluid Level and Temp. Gauge
4	With the machine on level surface, check the heat transfer oil level while at a temperature of 70°F. The oil should be at the full mark on the dipstick. DO NOT overfill or spillage may occur when the oil is heated and expands. See Fig. 5.1 Heat Transfer Oil Dipstick
5	Make sure all toggle switches are turned “OFF” and all temperature control dials are set to their minimum settings.
WARNING	
	<p>The safe operation of this machine is the operator’s responsibility.</p> <p>Use extreme care when operating this machine; safety is the result of being careful and paying attention to details. Remember the propane flame is approximately 2,200°F. Some exposed parts of the machine reach 500°F, the sealant 400°F, and the hydraulic fluid 180°F.</p> <p>Always put on protective clothing, gloves, hard-soled shoes, and safety glasses or a face shield. Be sure that all joints and fittings are tight and leak proof. Immediately replace any hose, which shows any signs of wear, fraying, or splitting. Tighten all bolts, nuts, and screws every 100 hours.</p>

Chapter 5 Operating Instructions



Fig. 5.1 Hydraulic Fluid Level and Temp. Gauge

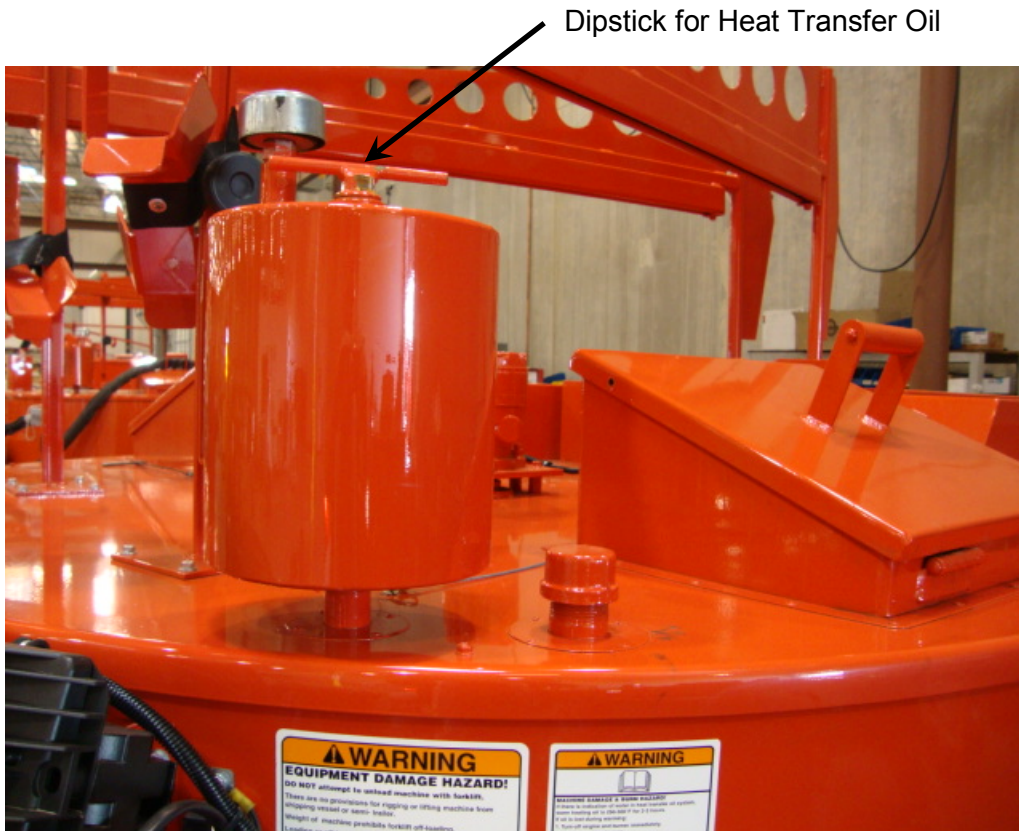

Fig. 5.2 Heat Transfer Oil Dipstick

Chapter 5 Operating Instructions

5.2 Machine Start Up for Electric Hose

Table 5-2 Starting the Burner for Electric Hose

Step	Action
1	Fully open the exhaust stack cover.
2	Start the engine. (Refer to the manufacturer's instructions for the engine).
3	Turn the "POWER" toggle switch in the control box to the "ON" position. The red light marked "BURNER" will illuminate indicating that the material and hot oil temperatures are below set point. When the red light goes off this indicates the material or oil temperatures are up to the set point. NOTE: Just because this light is illuminated does not indicate the burner is actually working.
4	Turn "HOSE SELECTOR" switch to "ELECTRIC". Note: Electric hose will only work if hose selector switch is in the electric hose position.
5	Set the heat transfer oil temperature at 500°F.
6	Set the material temperature to the manufacturer's recommended temperature.
	CAUTION
	If the burner does not ignite the first time, turn the "POWER" toggle switch to the "OFF" position. Turn the toggle switch to "ON" again; the burner should ignite. If the burner still does not ignite, refer to 8.0.1 Symptoms: Burner will Not Ignite to determine the malfunction.
	Important: The solid material in the tank melts first around the walls, bottom, and around the center tower of the tank. The material temperature sensor is located by the wall, therefore, it is possible that at the beginning of the melting process the indicated temperature reaches operating value, but the material between to the center tower and the outside wall of the tank is still solid. This is normal, and when the heated hose is ready for operation, most of the material in the tank will be melted and heated to the proper application temperature.
7	Allow the heat transfer oil to continue to heat.
8	When the material reaches 275°F, the mixer light will illuminate which indicates the mixer can be engaged by turning the toggle switch at the control panel to "FORWARD" position. If the mixer does not move, allow the material to heat longer. Note: Mixer speed is preset at the factory and cannot be adjusted. The mixer cannot be engaged until the material reaches 275°F.
	CAUTION
	Jamming the mixer can cause the hydraulic oil to overheat and damage the machine.
9	The hose automatically turns "ON" when the material temperature reaches 275°F. The red light marked "HEATED HOSE" will illuminate when the hose control is calling for heat.
10	To heat the driver's side hose, turn "ON" the power switch in the driver's side control box. Turn "HOSE SELECTOR" switch to "ELECTRIC". Note: Driver's side hose will not turn "ON" until material temperature reaches 275°F.

Chapter 5 Operating Instructions

Table 5-2.1 Starting the Burner for Electric Hose (continued)

Step	Action
11	Adjust the temperature dials of each hose to the manufacturer's recommended temperature. Note: The hose reaches operating temperature in approximately 30 minutes.
12	After each hose reaches the temperature set point, the light in the control boxes marked "HEATED HOSE" turns off.
13	Once the hose reaches 325° F the red light marked "PUMP" will illuminate indicating that the temperature interlock will allow operation of material pump. Important: The hose must reach 325°F before dispensing can take place. If the hose does not dispense when the trigger is activated, allow the material to heat longer. If the hose still does not dispense, shut the machine down, locate and remove the plug in the line. The oven must be at 300°F for 20 minutes before attempting to pump. The oven temperature can be regulated by opening the slide gate to increase temperature or close slide gate to decrease temperature. Slide gate is located on passenger side.
14	Remove hose and wand from transport position and place wand tip in shoebox.
15	When sealant reaches application temperature, open "TANK, and RECIRCULATION valves".
16	Reverse pump for 3-5 minutes by turning the pump toggle switch to "PUMP REVERSE". When pump turns freely, return switch to "ON ELECTRIC" position.
17	Depress wand trigger to recirculate material back into the tank to get material flowing freely through the pump. Ensure wand tip is fully inserted into the shoebox with the door closed until material is flowing freely.
18	When application of material is desired, open "APPLICATOR VALVE" and close "RECIRCULATION VALVE". See Table 5-8 Dispensing the Material – Electric Hose
	<div style="background-color: yellow; text-align: center; padding: 5px;">CAUTION</div> <p>DO NOT twist or kink the hose. Avoid sharp bends and continuous twisting by maintaining a minimum 10-inch bend radius. DO NOT use a setting on the hose controller if more than 400°F. DO NOT move or bend the hose when cold: it can cause damage to the hose. DO NOT leave the hose cycling for longer than 30 minutes without dispensing material; coking can occur and permanently damage the hose. DO NOT remove the hose from the boom during operation or kinking will occur.</p> <p>Important: It is strongly recommended that the hose be stored in the boom (locked position) when not in use or when in transit. This will prevent twisting or kinking.</p>

Chapter 5 Operating Instructions

5.3 Altitude Compensation System

This unit may be equipped with an Altitude Compensation System. If so, there will be a small boxed housing mounted right below the engine start key panel on the engine mount cross member. The system is automatic during most operating conditions. However, if the machine is taken from above or below an altitude of 2,624 ft. (800 Meters) while the engine is running, the engine will need to be stopped and then restarted. There is a yellow indicator light that illuminates when the machine is above 2,624 ft. (800 Meters) indicating that the system is active.

5.4 About the Heated Hose, Wand, Valve, and Tip Guard

The Heated Hose

The heated hose supplied with the machine is Teflon-lined with steel over braid. It has a heating element, which runs the length of the hose to heat the material within the hose. The hose is covered with high temperature, durable rubber.

The Wand

The wand has an aluminum tube to protect both the wand and the operator. The pistol grip actuator is equipped with an electric switch which, when depressed, sends a signal to actuate the pump. The wand is equipped with a trigger lock to prevent accidental pump actuation when it is not pumping material. The trigger must be in the "LOCKED" position at all times except when intentionally pumping material.

The Valve

The wand has a disposable duckbill valve on the end, which shuts off the flow of material when the pump is turned off and prevents excessive dripping of material. This valve also directs the material into a stream for easy application into the crack. Other sealing tips are available. See [10.0 Tools and Accessories](#) for other sealing tips and options.

Tip Guard

The wand has a Tip Guard installed at the factory only when a duckbill is installed. This Tip Guard is not required when using sealing disk or dripless tip adapter. The purpose of this guard is to prolong the life of the duckbill and to protect the operator in the event of a duckbill failure. Ensure this guard is installed properly before operating equipment. See below.

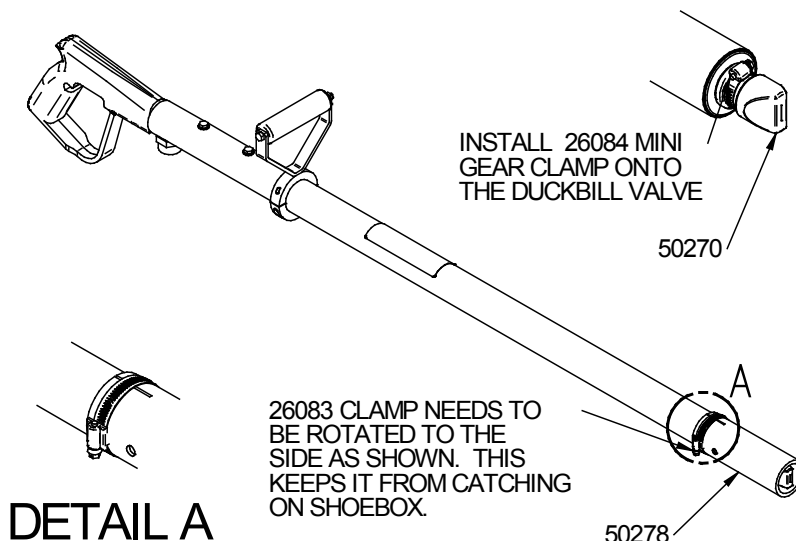

Chapter 5 Operating Instructions

5.5 Electric Hose Care and Cautions

Table 5-3 Electric Hose Care

Step	Action
	CAUTION
	Twisting and kinking of the electric hose (used on BAX, Super Shots, and EZ Series Melters) causes the hose to fail; the electric heating wires are shorted out to the metal hose cover and the hose stops heating. This type of failure is not covered under the CrafcO warranty.
1	Set the hose temperature at 380°F, or manufacturer recommended operating temperature.
2	Allow the hose to be turned "ON" and heating for a minimum of 30 minutes.
3	Make sure the hose swivel between the hose and wand moves freely. Note: Do not twist or bend the hose over sharp edges such as the edge of the frame or tank. CrafcO, Inc. recommends you do not work directly under the boom; this may cause damage to the hose.
4	Follow all machine instructions in this manual.
	CAUTION
	Hose damage occurs if: The hose is bent or moved when cold. The hose is twisted or bent at a sharp radius. The hose is moved before being heated a minimum of 30 minutes and set at 380°F. The operator crosses over or under the hose causing the wires between the hose and wand connection to twist or wrap up. The swivel is cold and is not flexible which can cause the hose to twist. The wiring between the hose and the wand is pulled, stressed, or used to support the wand.

5.6 Storing the Electric Hose for Transport

Table 5-4 Hose for Transport Instructions

Step	Action
1	Leave the hose in the boom, swing the boom clockwise (D.S. Hose) and counterclockwise (P.S. Hose) towards the front of the machine and lock the booms into position with the latch provided.
2	Place the wand in the wand holder and lock the wand into position with the latch provided.

Chapter 5 Operating Instructions

5.7 Machine Start Up for Standard Hose

Table 5-5 Starting the Burner for Standard Hose

Step	Action
1	Fully open the exhaust stack cover.
2	Start the engine. (Refer to the manufacturer's instructions for the engine).
3	<p>Turn the "POWER" toggle switch in the control box to the "ON" position. The red light marked "BURNER" will illuminate indicating that the material and hot oil temperatures are below set point. When the red light goes off this indicates the material or oil temperatures are up to the set point.</p> <p>NOTE: Just because this light is illuminated does not indicate the burner is actually working.</p>
4	Turn "HOSE SELECTOR" switch to "STANDARD".
5	Set the heat transfer oil temperature at 450°F.
6	Set the material temperature to 350°F.
	CAUTION
	If the burner does not ignite the first time, turn the "POWER" toggle switch to the "OFF" position. Turn the toggle switch to "ON" again; the burner should ignite. If the burner still does not ignite, refer to 8.0.1 Symptoms: Burner will Not Ignite to determine the malfunction.
	Important: The solid material in the tank melts first around the walls, bottom, and around the center tower of the tank. The material temperature sensor is located by the wall, therefore, it is possible that at the beginning of the melting process the indicated temperature reaches operating value, but the material between to the center tower and the outside wall of the tank is still solid. This is normal, and when the heated hose is ready for operation, most of the material in the tank will be melted and heated to the proper application temperature.
7	Allow the heat transfer oil to continue to heat.
8	<p>When the material reaches 275°F, engage the mixer by turning the toggle switch at the control panel to "FORWARD" position. If the mixer does not move, allow the material to heat longer.</p> <p>Note: Mixer speed is preset at the factory and cannot be adjusted. The mixer cannot be engaged until the material reaches 275°F.</p>
	CAUTION
	Jamming the mixer can cause the hydraulic oil to overheat and damage the machine.
9	<p>The pump light will come "ON" when the material temperature reaches 275°F indicating the temperature interlock will allow operation of either material pump.</p> <p>NOTE: Hose temperature display will not read an accurate pumping temperature until sealant is being pumped through the hose.</p> <p>Important: The oven must be at 300°F for 20 minutes before attempting to pump. The oven temperature can be regulated by opening the slide gate to increase temperature or close slide gate to decrease temperature. Slide gate is located on passenger side.</p>

Chapter 5 Operating Instructions

Table 5-5.1 Starting the Burner for Standard Hose (continued)

Step	Action
10	To use the driver's side hose, turn "ON" the power switch in the driver's side control box. Turn "HOSE SELECTOR" switch to "STANDARD".
11	When sealant reaches 325°F, open "TANK and RECIRCULATION valves, and close APPLICATOR VALVE".
12	Reverse pump for 3-5 minutes by turning the pump toggle switch to "PUMP REVERSE" position. When pump turns freely in reverse, return switch to "ON STANDARD" position. This circulates hot material from bottom of tank back on top of cold material in the tank.
13	Increase heat transfer oil temperature to 500°F and material temperature to manufacturers recommended application temperature (Approx. 380°-400°F).
14	When application of material is desired, remove hose from oven and connect to wand assembly (Hand tight only). Insert wand tip fully into shoebox with hand wand valve in "OPEN" position.
15	Open the "APPLICATOR VALVE", close "RECIRCULATION VALVE". See Table 5-9 Dispensing the Material – Standard hose

5.8 Loading Material into the Sealant Tank

This unit is equipped with a safety interlock system on the loading door. This system disables the mixer hydraulic system when the lid is open to stop the mixer from turning. This is a safety feature for the operator and should never be disabled for any reason.

CAUTION

Personal injury could occur if this safety system is disabled.

Table 5-6 Loading Material into the Sealant Tank

Step	Action
	WARNING
	Following this procedure prevents hot material from getting on operators and causing severe burns. Never throw blocks of material directly into tank. Hot material splash hazard will result.
1	To load material into the sealant tank first open the lid.
2	Place the solid material on the lid then close the lid. For approximate material volume see Table 5-7 Material Tank Depth Chart
3	Continue adding solid material at intervals to allow the mixer to rotate without jamming. Note: If blocks of solid material are added too quickly, jamming results and slows down the melting process.
	Note: When sealant placement volume is low, or the crew has stopped working for lunch, hot oil and material temperatures can equalize. To lower material temperature add a few blocks of cold sealant. This may not be an option if the tank is full.

Chapter 5 Operating Instructions

5.8.1 Material Tank Depth Chart

Table 5-7 Material Tank Depth Chart

DEPTH OF MATERIAL TANK	CAPACITY IN GALLONS BOTTOM UP	CAPACITY IN LITERS BOTTOM UP	CAPACITY IN GALLONS TOP DOWN	CAPACITY IN LITERS TOP DOWN
1	13.51	51.14	381.26	1443.23
2	27.16	102.81	367.23	1390.12
3	40.93	154.94	353.2	1337.01
4	54.70	207.06	339.17	1283.90
5	68.47	259.19	325.14	1230.79
6	82.24	311.31	311.11	1177.68
7	96.01	363.44	297.08	1124.57
8	109.78	415.56	283.05	1071.46
9	123.55	467.69	269.02	1018.35
10	137.32	519.81	255.25	966.23
11	151.09	571.94	241.48	914.10
12	164.86	624.06	227.71	861.98
13	178.63	676.19	213.94	809.85
14	192.40	728.31	200.17	757.73
15	206.17	780.44	186.4	705.60
16	219.94	832.56	172.63	653.48
17	233.71	884.69	158.86	601.35
18	247.48	936.81	145.09	549.23
19	261.28	989.05	131.32	497.10
20	275.25	1041.93	117.55	444.98
21	289.27	1095.01	103.78	392.85
22	303.29	1148.08	90.01	340.72
23	317.31	1201.15	76.24	288.60
24	331.34	1254.26	62.47	236.47
25	345.37	1307.37	48.7	184.35
26	359.40	1360.48	34.93	132.22
27	373.43	1413.59	21.16	80.10
28	387.46	1466.70	7.39	27.97
28.56	395.29	1496.34	0	0.00

Chapter 5 Operating Instructions

5.9 Dispensing the Material

Table 5-8 Dispensing the Material – Electric Hose

Step	Action
WARNING	
	<p>Put on protective clothing, gloves, hard-soled shoes, and face shield or safety glasses when operating or filling this machine. Read the entire manual before operating the machine.</p> <p>Never point the wand at any part of the body or at any other person. Hot material can cause severe burns.</p> <p>Important: Some difficulty may be encountered when starting up on cold days. Although the wand is designed to heat the material all the way down to the tip, on cold days you can place the tip of the wand into the shoebox to facilitate material melting in the valve. Insert the wand tip for only a short time before proceeding.</p>
1	When the material and hose have reached manufacturer’s application temperature, you are ready to dispense material.
2	Turn the pump speed control to the lowest setting by turning the speed control knob fully clockwise.
3	Insert the wand tip into the shoebox, depress trigger on the wand and slowly increase pump speed until the pump motor starts to turn.
4	<p>Adjust the pump speed for the desired flow rate for the application. The rate of flow may be varied while the pump is running.</p> <p style="text-align: center;">CAUTION</p> <p>Never open flow control more than 2 full turns when using an electric hose as this will cause premature material pump wear.</p> <p>Important: It may be necessary to use the recirculation with the electric hose anytime the machine is not going to be used for more than 5-10 minutes when the ambient temperature is below 40°F or not being used for 20-30 minutes in warmer weather. This is critical after material is up to operating temperature and burner is running intermittently, the oven will cool and all material in the plumbing and pump will solidify. To get the oven hot enough to start pumping again, add several blocks of sealant to lower the material temperature enough to cause burner to ignite. This may not be an option if the tank is already full.</p>

Chapter 5 Operating Instructions

Table 5-9 Dispensing the Material – Standard hose

Step	Action
WARNING	
	<p>Put on protective clothing, gloves, hard-soled shoes, and face shield or safety glasses when operating or filling this machine. Read the entire manual before operating the machine.</p> <p>Never point the wand at any part of the body or at any other person. Hot material can cause severe burns.</p>
1	When the material has reached manufacturer’s application temperature, you are ready to dispense material.
2	Turn the pump speed control to the lowest setting by turning the speed control knob fully clockwise.
3	Insert the wand tip into the shoebox, open the ball valve on the wand and adjust the control valve to get close to the desired material flow for the application.
4	Open recirculation valve to get the desired flow rate.
5	This method of operation will give maximum pump life. If the sealant does not flow from the applicator wand, close hand wand valve and place hose and wand back into the oven to allow the sealant to become more liquid, and then repeat procedure.
6	Once sealant is flowing freely, reverse pump and install desired sealing tip or disk and you are ready to begin sealing. See Section 10.0 Tools and Accessories for other sealing tips and disk.
CAUTION	
Extreme care should be taken when changing or installing sealing tips. Always engage pump reverse if sealant is hot. Hot sealant can cause severe skin burns.	

5.10 Shutting Down and Cleaning Out the Machine

When shutting down the machine for the day, CrafcO recommends leaving the melter about half full with material. This will give a fairly rapid heat up rate in the morning, but allows enough material to start dispensing right away when the material becomes molten.

Chapter 5 Operating Instructions

Table 5-10 Shutting Down with an Electric Hose

Step	Action
1	Leaving the hose in the boom, swing the boom clockwise towards the front of the machine and lock the boom into position with the latch provided.
	CAUTION
	DO NOT kink or twist the hose or permanent damage may result.
2	Place the wand in the wand holder and lock the wand into position with the latch provided.
3	Reverse the pump while removing tip adapter and or duckbill. Continue to reverse for approximately 30 more seconds.
4	Close the "APPLICATOR VALVE" and "TANK VALVE".
5	Turn the mixer toggle switch to the "OFF" position.
6	Turn the "POWER" switch to the "OFF" position.
7	Stop the engine by turning the key to the "OFF" position.

Table 5-11 Shutting Down with a Standard Hose

Step	Action
1	Close recirculation valve and reverse the pump for approximately 3 minutes.
2	Close the "APPLICATOR VALVE" first, and then close the "TANK VALVE".
3	Turn the mixer toggle switch to the "OFF" position.
4	Turn the "POWER" switch to the "OFF" position.
5	Stop the engine by turning the key to the "OFF" position.
6	Remove the wand from the hose.
7	Remove the hose from the boom and wrap on hose hanger located in the oven. Ensure the hose is not touching the tank wall or plumbing.

Chapter 5 Operating Instructions

5.11 Storing the Machine

Store the machine in an area where moisture cannot enter the heating system such as heat transfer oil tank, etc. Extended down time can cause moisture build up in the heating tank.

Evidence that moisture has collected in the heat transfer oil is a constant popping noise. If this popping noise is heard, warm the heat transfer oil to 300°F for two to three hours to evaporate the moisture. Failure to follow this procedure will cause the heat transfer oil to overflow the tank resulting in possible machine damage and/or personal injury.

Best practice is to check in the material tank prior to starting the burner. If water is present, try and remove as much as possible, heat the material to 300°F for two to three hours to evaporate the moisture. Failure to follow this procedure will cause the material to overflow the tank resulting in possible machine damage and/or personal injury.

Store the machine for longer periods with the material tank empty.

Chapter 6 Maintenance Instructions

6.0 Maintenance Instructions

This chapter contains all normal maintenance instructions to properly maintain your machine.

6.1 Engine

Refer to the manufacturer's operating and maintenance instructions for the engine.

6.2 Hydraulic System

Check hydraulic fluid daily.

Change hydraulic filter every 250 hours of machine operation. Replace if necessary.

Change hydraulic fluid every 500 hours of operation.

6.3 Heat Transfer Oil

Check the oil level at the start of every day.

Change the oil every 500 hours of machine operation or 1 year, whichever comes first. Failure to follow this oil change interval will result in machine damage.

6.4 Wheel Bearing

Pack the wheel bearing every 24,000 miles or every two years, whichever comes first. Use a good grade of bearing grease.

6.5 Material Sensor Tube

Check for heat transfer oil in tube every 50 hours of operation. 2 ounces required.

6.6 Cleaning Material Tank and Sensor Area

The material tank needs to be cleaned every year or as needed for proper operation. As the machine is used, material builds up around the tank walls and sensor guard. The built up material prevents heat from getting to the fresh material and causes longer heat up times. The built up material will also prevent the material temperature sensor from reading as accurately because it becomes insulated from the fresh material. The coked material needs to be scraped or chipped from the tank walls. The area between the sensor and sensor guard needs to be cleaned also for proper temperature sensing. An air chisel with various sized blades usually works best to break up the material and remove it from the walls. Once the walls and sensor guard areas are cleaned, remove all the loose chunks from the tank, and vacuum out any smaller pieces

6.7 Lug Nuts

Torque all nuts/bolts before first road use and after each wheel removal. Check and torque after the first 10 miles, 25 miles, and again at 50 miles. Check periodically thereafter.

Torque in stages as follows:

First stage 20-25 foot-pound (ft-lb)

Second stage 50-60 foot pound (ft-lb)

Third stage 90-120 foot pound (ft-lb)

Tighten bolts and nuts in the sequence shown in [Figure 6.1 Lug bolt Tightening Sequence](#)

Chapter 6 Maintenance Instructions

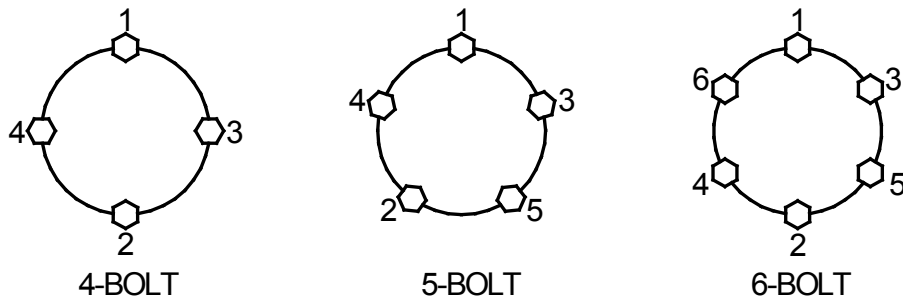

Fig. 6.1 Lug bolt Tightening Sequence

6.8 Brakes

Check the brakes daily.

6.9 Tongue Jack

Lubricate the tongue jack, using a good grade of bearing grease.

6.10 Temperature control Calibration

Check the control knob calibration weekly. Calibrate by turning the knob counterclockwise. If the marks do not align, loosen screw in knob and align the line on the control knob with the calibration mark on the scale plate. (See [Figure 5.2 Heat Transfer Oil Dipstick](#))

6.11 Burner Flame Retainer

Check the flame retainer every 500 hours. Failure to maintain this part will cause damage to the hot oil tank. Notice the 3/4" extension (See [Fig. 6.3 Flame Retainer](#)), if this is burned off it must be replaced.

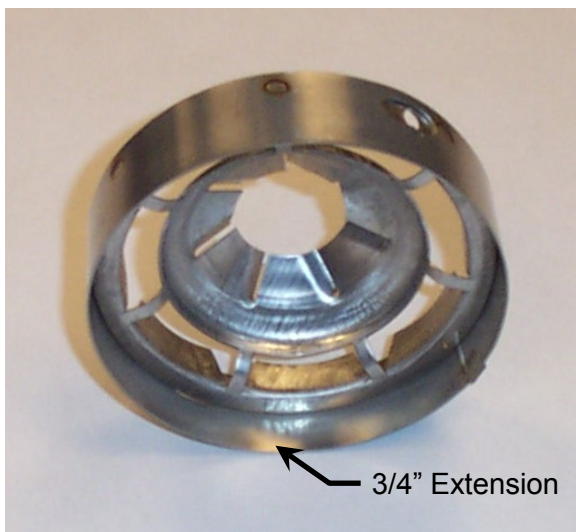

Fig. 6.2 Flame Retainer

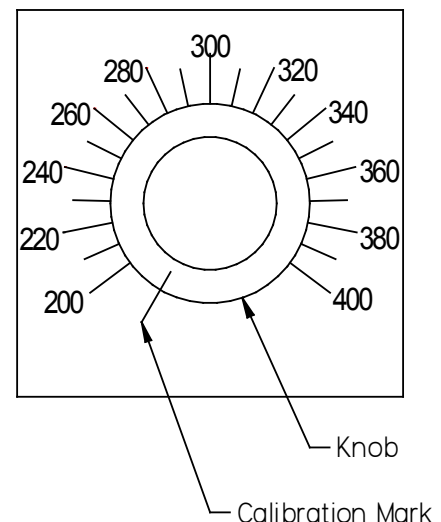

Fig. 6.3 Temperature Control Calibration

Chapter 6 Maintenance Instructions

6.12 Maintenance Chart

Table 6-1 Maintenance Chart

Possible Cause	Procedure	Hours			
		8	50	250	500
Engine check oil level	Refer to the manufacturer's instructions for the engine	X			
Other engine maintenance	Refer to the manufacturer's operating and maintenance instructions for the engine.				
Material Sensor Tube	Check for HTO fluid		X		
	Add	As needed			
Heat Transfer Oil	Check	X			
	Change				X
Hydraulic Oil	Check	X			
	Change				X
Hydraulic Oil Filter	Change			X	
Burner	Check burner box insulation				X
	Clean CAD cell.				X
	Check Electrodes				X
	Burner Flame Retainer				X
	Replace burner nozzle				X
Wheel Bearings	Clean and re-pack using a good grade of bearing grease	Every 24,000 miles or two years			
Tongue Jack	Grease using a good grade of bearing grease.	Once a year			
Compressor	Refer to manufacturer's instructions for the compressor				
Material Tank	Scrape out built up material in the material tank	Once a year or as needed			
Material Sensor Guard	Scrape out built up material around guard				X

For a list of parts required for maintenance see [Table 6-3 General Maintenance Parts](#).

Chapter 6 Maintenance Instructions

6.13 Service Instructions

Table 6-2 Service Instructions

Step	Action
1	Do a general inspection of the machine at least once a week.
2	Replace all worn or damaged parts. Note: Keep regular replacement items in stock for emergency repairs to prevent costly downtime. See Table 6-4 Recommended Spare Parts
3	Make necessary adjustments and tighten all loose nuts or screws.
4	Watch for leaks. Tighten fittings or repair as necessary.
5	Clean the external surfaces of the machine at regular intervals. Note: Refer to the material manufacturer's instructions for recommendations.
6	Follow the recommended maintenance per Table 6-1 Maintenance Chart

For service, find a list of authorized Distributors and service centers at Crafco.com/Distributors.

6.14 General Maintenance Parts

Table 6-3 General Maintenance Parts

Quantity	Description	Machine	Part No.
1	Fuel Filter	All	41867
1	Oil Filter	46500SB 46500EB	45381
1	Air Filter	46500SB	45382
1	Air Filter	46500EB	45348
1	Nozzle, Burner	All	44785
1	Burner Flame Retainer	All	44786
1	Packing, Material Pump	All	29990S
1	Hydraulic Oil Filter	All	45438
Table 6-5	Hydraulic Oil	All	Table 6-5
Table 6-5	Heat Transfer Oil	All	Table 6-6

Chapter 6 Maintenance Instructions

6.15 Recommended Spare Parts

Table 6-4 Recommended Spare Parts

Quantity	Description	Machine	Part No.
1	Temperature Controller, Material	All	51672
1	Temperature Controller, Electric Hose	46500EB,	51691
1	Temperature Controller, Hot Oil	All	43391
1	Temperature Controller, Material	46500SB,	43397
1	DC Controller	All	42335
1	Coupling, Fuel Pump	All	41970
1	Electric Hose, 15'	46500EB,	51731
1	Solenoid	All	39602

6.16 Recommended Fluids and Lubricants

Table 6-5 Recommended Fluids and Lubricants

Application	Recommended	Full Point	Machine No.
Fuel	#1 Cold Climate #2 Warm Climate	30 Gals.	All Models
Engine Oil	Refer to engine manual	3 Qt.	PN 46500SB
		6.7 Qt.	PN 46500EB
Hydraulic Oil	Shell AW Hydraulic 46	24 Gals.	All Models
Heat Transfer Oil	Shell Turbo T 68 (Group II)	48 Gal.	All Models
Legend: PN 46500EB EZ1500 Double Pumper Electric Base PN 4650SB EZ1500 Double Pumper Standard Base			

Chapter 6 Maintenance Instructions

6.17 Applicable Brands of Heat Transfer Oil

Table 6-6 Applicable Brand of Heat Transfer Oil

Manufacturer	Product Name	Crafco Heat Transfer Fluid
Chevron	Heat Transfer Oil Grade 46	Shell Turbo T 68 (Group II)
Citgo	Hytherm Oil 46	Shell Turbo T 68 (Group II)
Conoco	Hydroclear Heat Transfer Oil	Shell Turbo T 68 (Group II)
Fina	Vulcan Heat Transfer Oil 46	Shell Turbo T 68 (Group II)
Lubrication Engineers	Heat Transfer Oil	Shell Turbo T 68 (Group II)
Exxon Mobile	Caloria HT 43	Shell Turbo T 68 (Group II)
Mobil	Mobiltherm 43	Shell Turbo T 68 (Group II)
Mobil	Mobiltherm 603	Shell Turbo T 68 (Group II)
Phillips 66	Heat Transfer Oil #3`	Shell Turbo T 68 (Group II)
Phillips 66	Magnus Oil 68	Shell Turbo T 68 (Group II)

CAUTION

The heat transfer oil in this machine is a grade that has been tested and recommended by Crafco, Inc. Using a grade of oil not specifically recommended by Crafco, Inc., is cause for warranties to be voided.

All oils subjected to high temperatures deteriorate with time and lose many of their characteristics. Tests conducted by Crafco, Inc. have determined that for best results and safety, the heat transfer oil in this machine must be drained and replaced with Crafco, Inc. recommended oil after five hundred (500) hours of machine operation or one (1) year, whichever occurs first.

6.18 Typical Heat Transfer Oil Specifications

ISO	68
Flash Point, COC	445°F
Viscosity @ 100°F-SUS	325
Viscosity @ 210°F-SUS	50
Viscosity Index	95-100
Pour Point	0°F
Carbon residue	1%

Chapter 6 Maintenance Instructions

6.19 Material Pump Replacement

Table 6-7 Material Pump Replacement

Step	Action
1	Close "TANK VALVE".
2	Remove the front of the heat compartment. This is not necessary but will make the job easier.
	WARNING
	The material in the sealant tank is extremely hot. Bodily contact with hot sealant can cause severe burns.
3	Remove the side access panel.
4	Remove the 6 bolts from both flanges of the double elbow and remove double elbow.
5	Remove the 8 bolts from the material suction pipe flange.
6	Remove the 4 bolts from the hydraulic motor and loosen setscrew in pump/motor coupling. Remove motor from pump motor mount.
7	Remove the 4 bolts from the pump base and remove pump from pump base.
8	Remove the material suction pipe and the flanged nipple assembly from the material pump. Note orientation of bolt holes in flanges.
9	Install material suction pipe and flanged nipple assembly into new pump.
10	Install material pump onto pump base. The 8 hole flange gasket P/N29060 will also need to be installed at this time using (8) 3/8-16 x 1" bolts, (2) flat washers per bolt (1 on each side of flange), lock washer, and upset hex nuts. Use (4) 1/2-13 x 1 3/4" bolts, flat washer, lock washer, and hex nuts to attach pump to pump base. Leave all hardware loose until everything is installed.
11	Install double elbow using new flange gaskets P/N29050, 3/8-16 x 1" bolts, (2) flat washers per bolt (1 on each side of flange), lock washer, and upset hex nut. Leave all hardware loose until everything is installed.
12	Install hydraulic motor on material pump using (4) 3/8-16 x 1 1/4" bolts and lock washers. Tighten setscrew on pump/motor coupling.
13	Tighten all bolts and nuts.
14	Replace heat compartment using (11) 1/4-20 x 3/4" bolts, flat washers, and lock washers.
15	Replace access panel using (3) #10 x 3/8 Self Tapping Screw.

Chapter 6 Maintenance Instructions

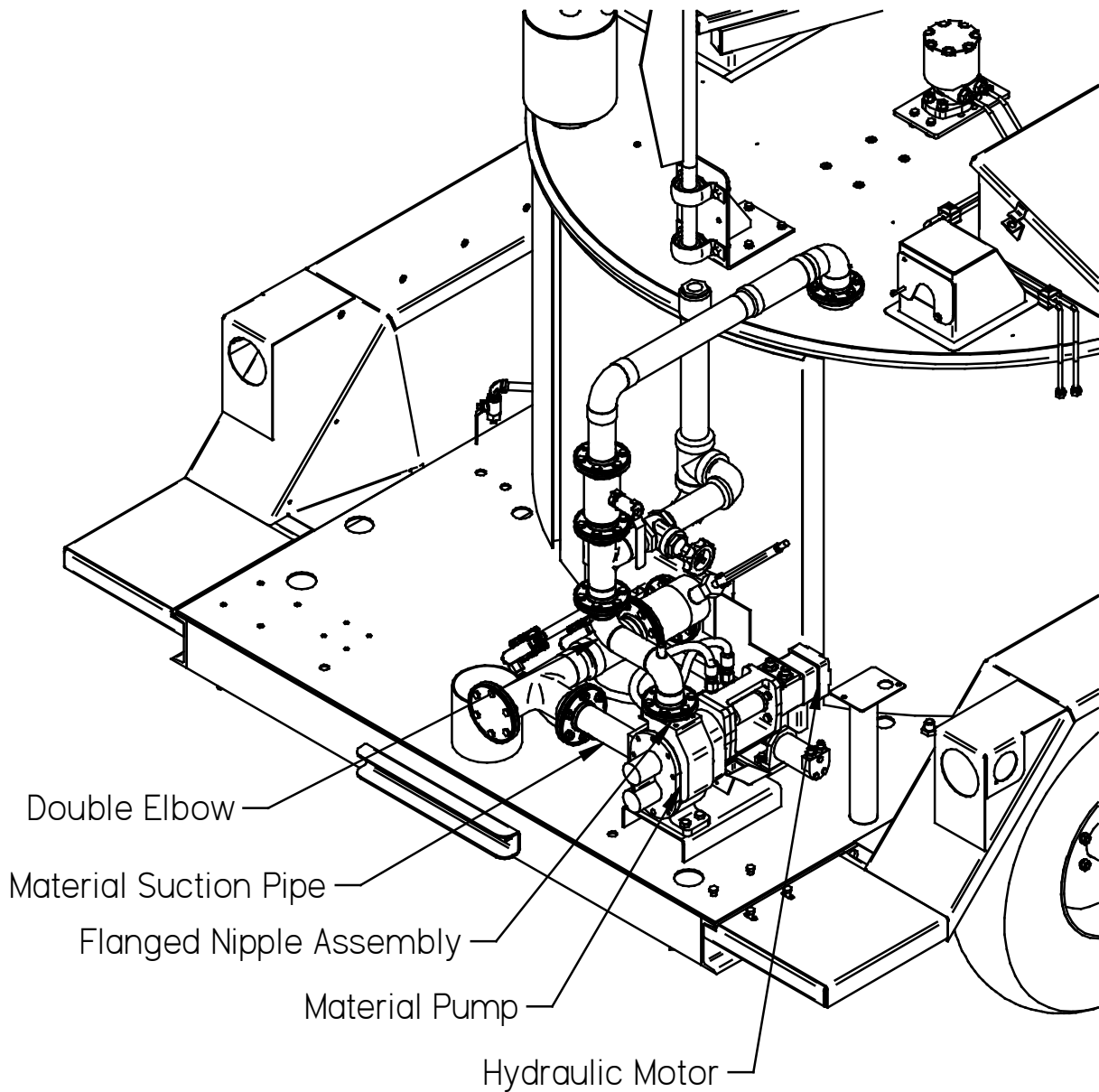

Fig. 6.4 Material Pump Replacement

Chapter 7 How to Use a Multimeter

7.0 How to Use a Multimeter

Melters use 12-volt direct current (DC) to power the burner, hydraulic valves, and trigger on electric wand. The DC power is from a 12-volt battery.

The electric hose and wand uses 24-volt 3-phase alternating current (AC). The AC power is from the generator which hangs under the radiator. This system has no reference to ground so there is no possibility of electrical shock unless you are between 2 of the phases. NOTE: ONLY CHECK AMPERAGE ON A HOSE WITH A CLAMP-ON AMP METER.

12-volt DC power has little danger of electrical shock. Care must still be taken when dealing with DC power systems because it is capable of producing large amounts of current.

7.1 Checking DC Voltage with a Multimeter

Connect the probes to the meter.

Set the range to a position that includes 12-volts or higher.

Touch the red probe to the positive side of accessory and black probe to ground. If the item you are checking has a ground wire attached then use that ground or you can use a non-painted surface on the frame.

7.2 Checking AC Voltage with Multimeter

Connect the probes to the meter (See [Figure 7.1 Standard Multimeter](#)).

Set the range to a position that includes 24-volts or higher.

There are three steps to test the generator voltage. All 3 values should be in the range of 24-30 volts AC.

- Touch red probe to the white wire of the generator and the black probe to the green wire of the generator.
- Next move black probe to black wire.
- Then move red probe to green wire.

7.3 Checking Resistance (Ohms)

Connect probes to the meter (See [Figure 7.1 Standard Multimeter](#)).

Note: When checking Ohms the circuit cannot be completed. This means one end of the wire will need to be disconnected.

7.3.1 How to Check Wire Continuity

Set the meter to “Audible Continuity”.

Now touch the probe to each end of the wire in question. The meter will read “0” on the screen and make an audible beep if the wire has continuity from end to end.

7.3.2 How to Check RTD Sensor

Set dial to Ohms Ω . If your meter has different ranges set to 2K or 2000 ohm range.

Touch one probe to each screw or wire of the sensor. The meter will read X.XX if in the 2K range or XXX.X if in the 2000 range.

Chapter 7 How to Use a Multimeter

7.4 Checking Amperage

The Multimeter can be used to check amperages under 10 amps in AC or DC current.

When checking the amperage of the electric hose **always use a clamp-on amp meter (See Figure 7.2 Clamp – On Amp Meter/Multimeter)**. The amperage in the hose can reach as high as 35 amps.

Clamp the meter around one wire at a time. Remember most clamp-on meters do not work on DC current.

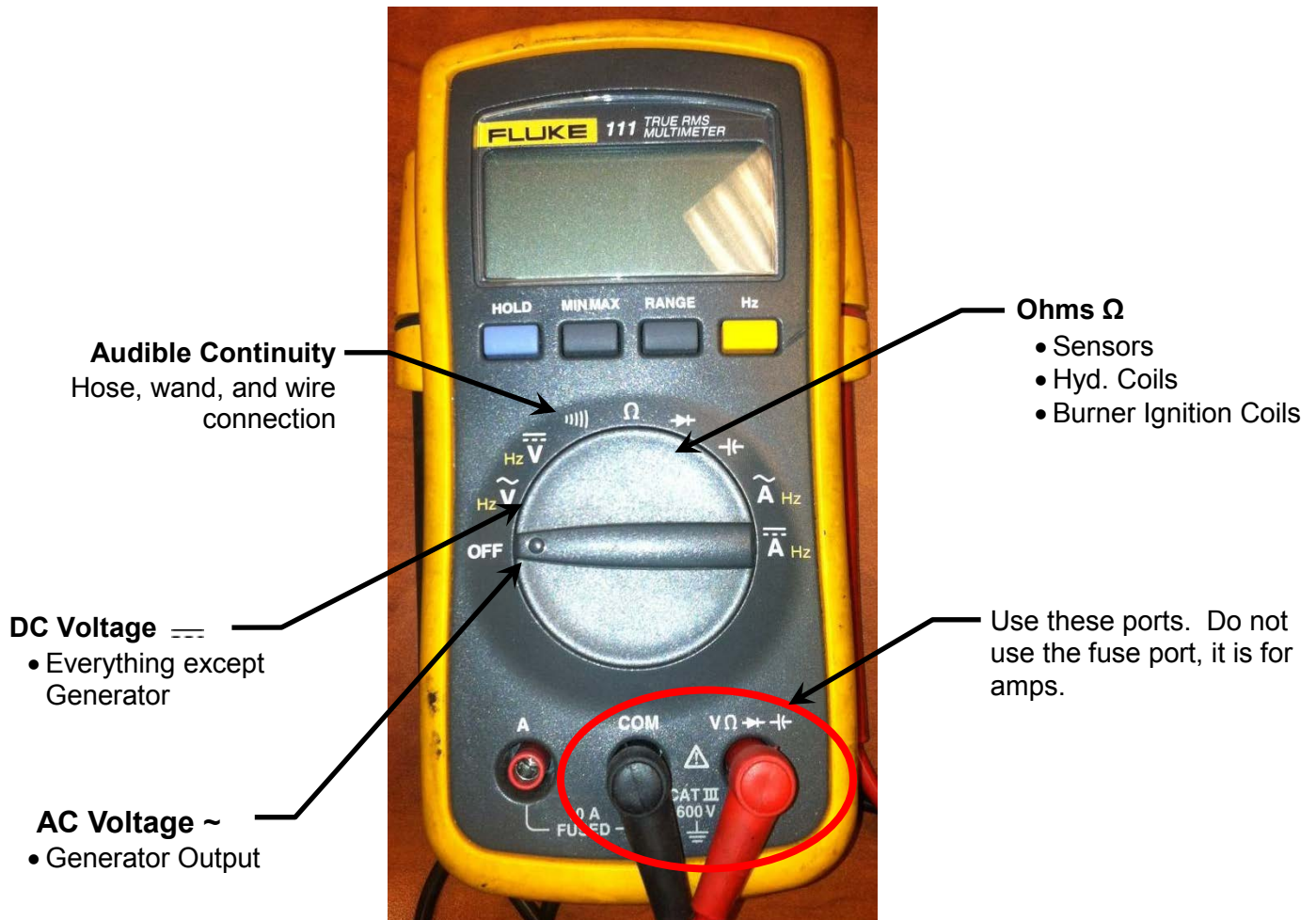

Fig. 7.1 Standard Multimeter

Chapter 7 How to Use a Multimeter

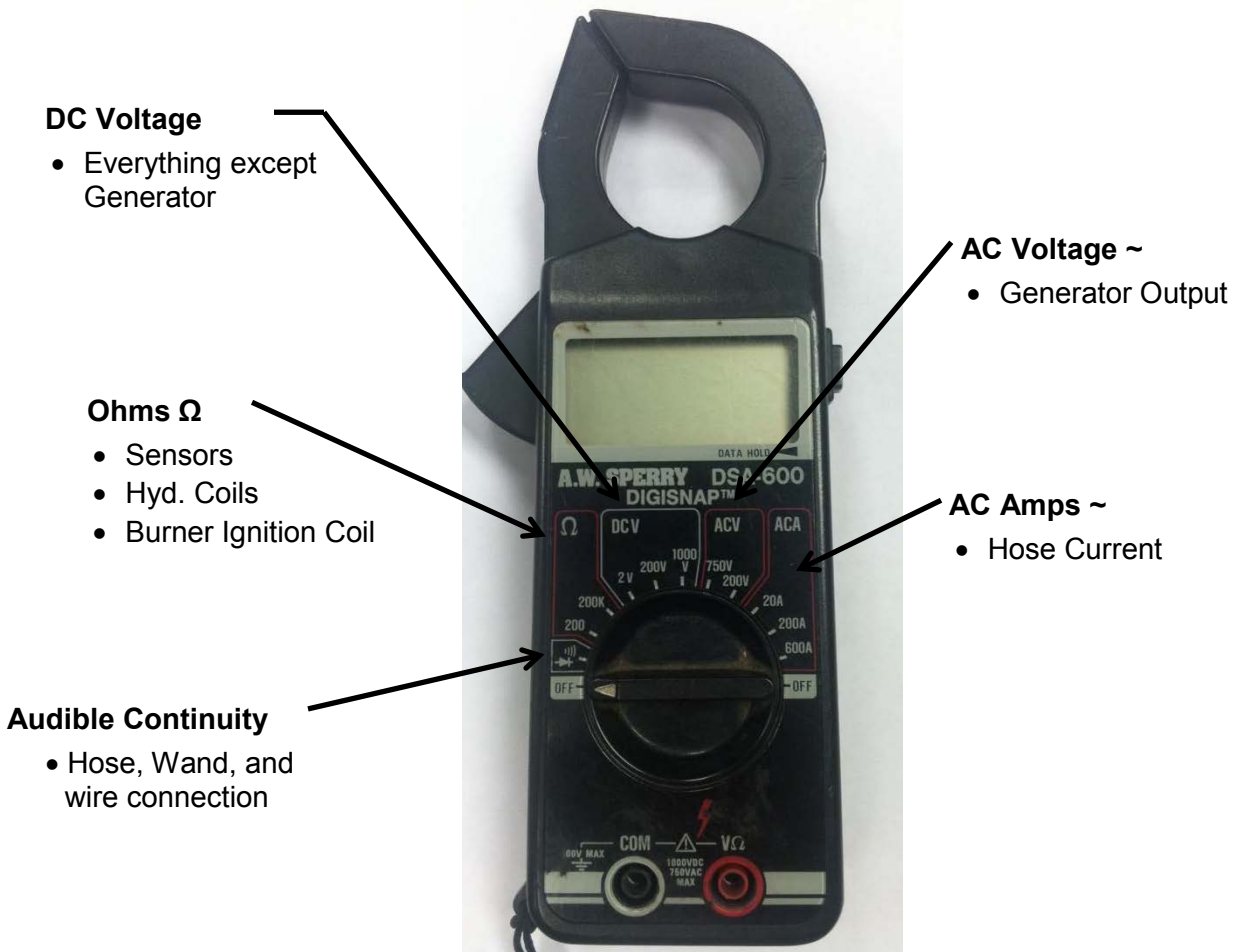

Fig. 7.2 Clamp – On Amp Meter/Multimeter

Chapter 8 Illustrated Parts List

8.0 Burner Troubleshooting

8.0.1. Symptoms: Burner will Not Ignite

Table 8-1 Basic Visual Burner Troubleshooting

Step	Possible Cause	If . . .
1	Is the engine running? NOTE: You can troubleshoot the burner without the engine running, but you must connect a battery charger to the battery and the ignition must be in the "ON" position	<ul style="list-style-type: none"> • Yes, go to Step 2. • No, start the engine.
2	Is the "POWER" toggle switch in the "ON" position?	<ul style="list-style-type: none"> • Yes, go to Step3. • No, turn the toggle switch to the "ON"
3	Is the red "Burner" light "ON"?	<ul style="list-style-type: none"> • Yes, go to Step 6. • No, go to Table 8-3 Burner Electrical Troubleshooting Step 4
4	Are both the Material and Hot Oil temperature dials set above the current temperatures?	<ul style="list-style-type: none"> • Yes, go to Step 4. • No, set the Material temperature according to the type of material you are using and the Hot Oil 100°F above the Material set point.
5	Does either readout display a -1? NOTE: This occurs only when there is a short in the sensor circuit.	<ul style="list-style-type: none"> • Yes, this indicates a short in the circuit. Check the RTD sensor for water under the cap causing a short. Also look for worn wires possibly shorting to frame between sensor and control box. • No, go to step 4a.
5a	Does either readout display a 1? NOTE: This occurs only when the sensor circuit is not completed.	<ul style="list-style-type: none"> • Yes, this indicates a break in one or both of the sensor wires between the RTD sensor and the PAKSTAT. Check for broken wires between sensor and PAKSTAT. • No, go to Step 6.
6	Is the circuit breaker tripped?	<ul style="list-style-type: none"> • Yes, reset by pushing in the button that popped out. • No go to Step 7.
7	Is the fuel level low or empty?	<ul style="list-style-type: none"> • Yes, fill with #2 diesel fuel. Then bleed the burner, see Table 8-12 Bleeding the Diesel Burner. • No, go to Step8

Chapter 8 Illustrated Parts List

Table 8-2 Basic Visual Burner Troubleshooting (continued)

Step	Possible Cause	If . . .
8	Is there smoke coming out of the exhaust stack?	<ul style="list-style-type: none"> • Yes, go to Table 8-13 Sealant is Heating Slowly. • No, go to Step 9.
9	Is your burner working properly, but it seems to take a while to reach operating temperature?	<ul style="list-style-type: none"> • Yes, go to Table 8-13 Sealant is Heating Slowly • No, Call Crafco, Inc. and speak to a customer service technician.

Note: Use [Fig. 8.1 Diesel Burner Schematic](#) while troubleshooting the burner electrical system.

Table 8-3 Burner Electrical Troubleshooting

Step	Possible Cause	If . . .
1	Is there 12Vdc between the 2 center terminals of the frame solenoid?	<ul style="list-style-type: none"> • Yes, go to 1a • No, check for poor connection or broken wire between frame solenoid and engine oil pressure switch white/red wire.
1a	Is there 12Vdc between the large terminal (red wire going to burner plug) of the frame solenoid and the black wire in the burner plug?	<ul style="list-style-type: none"> • Yes, go to Step 4. • No, go to Step 1b.
1b	Is there 12Vdc between the other large terminal (red wire going to the circuit breaker) of the frame solenoid and the ground wire attached to the mounting bolt?	<ul style="list-style-type: none"> • Yes, replace frame solenoid. • No, go to step 2.
2	Is there 12Vdc between the circuit breaker (red wire going to frame solenoid) located under the battery and the ground lug on the battery tray?	<ul style="list-style-type: none"> • Yes, check for loose or broken wires between circuit breaker and frame solenoid. • No, go to Step 2a.
2a	Is there 12Vdc between the circuit breaker (red wire going to battery positive cable) and the ground lug on the battery tray?	<ul style="list-style-type: none"> • Yes, wait 15 seconds then repeat step 2. • If still no voltage then replace circuit breaker. • No, go to step 2b.
2b	Check for loose or broken wires between circuit breaker and battery positive cable.	<ul style="list-style-type: none"> • Yes, replace or repair damaged wire and repeat Step 3. • No, go to step 3.

Chapter 8 Illustrated Parts List

Table 8-4 Burner Electrical Trouble shooting (continued)

Step	Possible Cause	If . . .
3	Is there 12Vdc between the positive and negative battery post? If this check is done while the engine is running the reading should 13.8 volts.	<ul style="list-style-type: none"> • Yes, then there should be 12Vdc on the battery side of the circuit breaker. • No, replace battery. • NOTE: If the reading is less than 13.8 volts while the engine is running the alternator needs to be rebuilt or replaced.
4	Find insulated quick connect between green wire and white wire that goes to burner plug. Is there 12Vdc between the green wire and a nearby ground source (black wire)?	<ul style="list-style-type: none"> • Yes, go to Table 8-9 Testing the DC Controller. • No, go to step 4a.
4a	Is there 12Vdc between green wire labeled "GRN-BRNR" on upper terminal blocks and nearby ground source (black wire).	<ul style="list-style-type: none"> • Yes, check for loose or broken wires between burner plug and terminal block. • No, go to Step 5.
5	Is there 12Vdc between gray wire labeled "GRY-2" and nearby ground source?	<ul style="list-style-type: none"> • Yes, replace terminal block. • No, go to Step 5a.
5a	Is there 12Vdc between terminal #7 gray wire and terminal #5 black wire of the hot oil PAKSTAT?	<ul style="list-style-type: none"> • Yes, check for loose or broken wires between terminal block and terminal #7 of the hot oil PAKSTAT. • No, go to Step 5b.
5b	Is there 12Vdc between terminal #6 gray wire and terminal #5 black wire of hot oil PAKSTAT?	<ul style="list-style-type: none"> • Yes, replace hot oil PAKSTAT. • No, go to Step 6.
6	Is there 12Vdc between gray wire labeled "GRY-3" on upper terminal blocks and a nearby ground source (black wire)?	<ul style="list-style-type: none"> • Yes, check for loose or broken wires between terminal block and terminal #6 of the hot oil PAKSTAT. • No, go to Step 6a.
6a	Is there 12Vdc between gray wire labeled "GRY-1" on upper terminal blocks and a nearby ground source (black wire)?	<ul style="list-style-type: none"> • Yes, replace terminal block. • No, go to Step 7.
7	Is there 12Vdc between terminal #4 gray wire and terminal #8 black wire of the material PAKSTAT?	<ul style="list-style-type: none"> • Yes, check for loose or broken wires between terminal block and terminal #4 of the material PAKSTAT. • No, go to Step 7a.

Chapter 8 Illustrated Parts List

Table 8-5 Burner Electrical Trouble shooting (continued)

Step	Possible Cause	If . . .
7a	Is there 12Vdc between terminal #3 orange wire and terminal #8 black wire of the material PAKSTAT?	<ul style="list-style-type: none"> • Yes, replace PAKSTAT. • No, go to step 7b.
7b	Is there 12Vdc between terminal #1 orange wire and terminal #8 black wire of the material PAKSTAT?	<ul style="list-style-type: none"> • Yes, check for loose or broken wires between terminal #1 and #3 of material PAKSTAT. • No, go to Step 7c.
7c	Is there 12Vdc between terminal #9 orange wire and terminal #8 black wire of the material PAKSTAT?	<ul style="list-style-type: none"> • Yes, check for loose or broken wires between terminal #9 and #1 of material PAKSTAT. • No, go to Step 8.
8	Is there 12Vdc between orange wire labeled "ORN-1" on upper terminal blocks and a nearby ground source (black wire)?	<ul style="list-style-type: none"> • Yes, check for loose or broken wires between terminal #9 of the material PAKSTAT and terminal block. • No, go to Step 8a.
8a	Is there 12Vdc between orange wire labeled "ORN-2" on upper terminal blocks and a nearby ground source (black wire)?	<ul style="list-style-type: none"> • Yes, replace terminal block. • No, go to Step 9.
9	Is there 12Vdc between terminal #3 orange wire and terminal #5 black wire on hot oil PAKSTAT?	<ul style="list-style-type: none"> • Yes, check for loose or broken wires between terminal #3 of the hot oil PAKSTAT and terminal block. • No, go to Step 10.
10	Is there 12Vdc between top terminal (orange wire) of power switch and nearby ground source (black wire)?	<ul style="list-style-type: none"> • Yes, check for loose or broken wires between top terminal power switch and terminal #3 of the hot oil PAKSTAT. • No, go to Step 11.
11	Is there 12Vdc between bottom terminal (red wire) of power switch and nearby ground source (black wire)?	<ul style="list-style-type: none"> • Yes, replace switch. • No, go to Step 12.
12	Is there 12Vdc between top terminal of circuit breaker (red wire) and nearby ground source (black wire)?	<ul style="list-style-type: none"> • Yes, check for loose or broken wires between top terminal of circuit breaker and bottom terminal (red wire) of power switch. • No, go to Step 12a.

Chapter 8 Illustrated Parts List

Table 8-6 Burner Electrical Trouble shooting (continued)

Step	Possible Cause	If . . .
12a	Is there 12Vdc between bottom terminal of circuit breaker (red wire) and nearby ground source (black wire)?	<ul style="list-style-type: none"> • Yes, replace circuit breaker. • No, go to Step 13.
13	Is there 12Vdc between “ACC” (red wire) of ignition switch and nearby ground source (black wire)?	<ul style="list-style-type: none"> • Yes, check for loose or broken wires between “ACC” of ignition switch and bottom terminal of circuit breaker. • No, go to Step 13a.
13a	Is there 12Vdc between “B” (blue wire) of ignition switch and nearby ground source (black wire)?	<ul style="list-style-type: none"> • Yes, replace ignition switch. • No, go to Step 14.
14	Is there 12Vdc between blue wire on starter solenoid and nearby ground source (black wire or bare metal on engine case)?	<ul style="list-style-type: none"> • Yes, check for loose or broken wire between starter solenoid and ignition switch. • No, go to step 14a.
14a	Check connections and condition of red battery cable?	<ul style="list-style-type: none"> • Yes, there should be 12Vdc at all previous steps. • No, replace battery cable.

Chapter 8 Illustrated Parts List

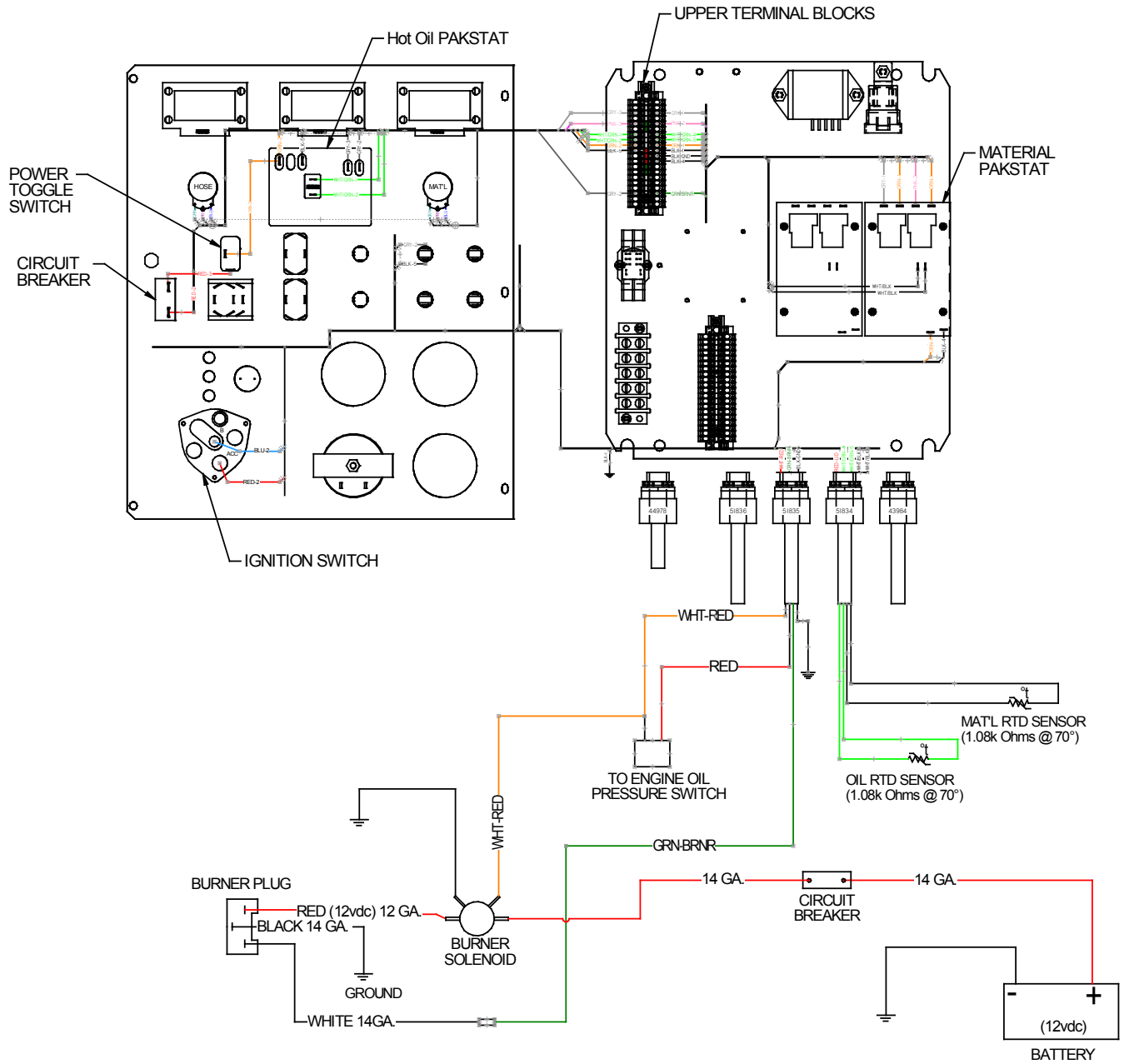

Fig. 8.1 Diesel Burner Schematic

Chapter 8 Illustrated Parts List

8.0.2. Excessive Smoke Coming Out of Exhaust Stack

Table 8-7 Smoke Coming Out of the Exhaust Stack

Step	Smoke Coming Out of the Exhaust Stack
1	White smoke indicates that there is too much air being forced through the burner. Loosen the Air Shutter screw and rotate the Air Shutter counter clockwise to reduce air. Refer to Fig. 8.3 Diesel Burner Air Settings , for the proper air settings and diagram.
2	Black smoke indicates that there is not enough air being forced through the burner. First check the air settings, if more air is required rotate Air Shutter clockwise. Refer to Fig. 8.3 Diesel Burner Air Settings
3	Refer to Fig. 8.3 Diesel Burner Air Settings to locate the following components. Using a 7/16" wrench, remove the copper fuel line nut attached to the nozzle line. Next remove the locking nut for the nozzle tube. Then loosen the locking tabs on the ignition coil and open the ignition coil. Remove the nozzle line assembly.
4	Using Fig. 8.2 Diesel Burner Electrode Adjustment , make sure the electrodes are in the correct position. Loosen the clamp holding the electrodes in place so they can be adjusted. Inspect the porcelain ceramic insulator for any cracks. Also check the tip of each of the electrodes to make sure they still have a sharp point and are not rounded off.
5	If it has been longer than 500 hours since the last time the burner nozzle was replaced, CrafcO recommends replacing the burner nozzle at this time.
6	Reassemble the burner, using the reverse order in Step 3.
7	Remove the burner box assembly by removing the four (4) 1/2" bolts, flat washer, lock washer, and nuts holding the burner box onto the trailer.
7a	Make sure the insulation inside the burner box is not soaked with diesel fuel.
7b	If the insulation is soaked with diesel fuel, you will need to replace the insulation.
7c	Reassemble the burner box.

8.0.3. Burner Lights but Shuts Down After 15 Seconds

Table 8-8 Burner Lights but Shuts Down After 15 Seconds

Step	Possible Cause	If . . .
1	Does the CAD EYE have soot or dirt on the lens?	<ul style="list-style-type: none"> • Yes, clean cad eye lens with a soft cloth. • No, go to Step 2.
2	Are the two yellow wires for the CAD EYE loose or broken?	<ul style="list-style-type: none"> • Yes, repair or replace as needed. • No, go to Step 3.
3	Is the CAD EYE faulty?	<ul style="list-style-type: none"> • Yes, replace CAD EYE. • No, call a CrafcO Inc. service technician.

Chapter 8 Illustrated Parts List

8.0.4. Testing the DC Controller

Table 8-9 Testing the DC Controller

Step	Bench Test DC Controller
1	Remove all wire nuts attaching the DC Controller to the burner.
2	Attach the black ground wire to the negative battery post.
3	Attach the red wire to the positive battery post.
4	Attach the white (Enable) wire to the positive battery post to start the test. (Genesis II Controllers will have a 15-second delay.) <ul style="list-style-type: none"> • Orange (Blower Motor) wire should have 12Vdc (all the time). • Blue (Igniter) wire should have 12Vdc.
5	Twist the yellow wires together (once voltage registers) on the orange, blue and purple wires. <ul style="list-style-type: none"> • Orange (Blower Motor) wire should maintain 12Vdc. • Blue (Igniter) wire should lose voltage after 15 seconds. • Purple (Valve) wire should maintain 12Vdc.
6	If any of the above tests fail, replace the DC Controller.

8.0.5. Burner Fuel Solenoid Testing

Table 8-10 Burner Fuel Solenoid Test

Step	Fuel Solenoid Test
1	Remove cord set from fuel solenoid.
2	Check the ohms between the terminals of fuel solenoid.
3	If the reading is between 15-25 ohms the coil is good.
4	If the reading is outside the above range or the meter indicates an open circuit, replace the fuel solenoid.

Chapter 8 Illustrated Parts List

8.0.6. Burner Ignition Coil Testing

Table 8-11 Burner Ignition Coil Test

Step	Ignition Coil Test
1	Make sure the burner is off. Open the ignition transformer (located above the blower) to expose the springs.
2	Check resistance between each of the springs and the ground (exposed metal on the burner).
3	The meter should read less than 2000 ohms. (Take note of the readings, you will use them in Step 5.)
4	Check resistance between both springs. (Take note of the reading, you will use it in Step 5.)
5	The igniter should be replaced if: <ul style="list-style-type: none"> • The difference between the two springs to ground resistance readings is greater than 20%. • Or the spring-to-spring resistance does not read approximately twice the spring to ground.

8.0.7. Bleeding the Diesel Burner

Table 8-12 Bleeding the Diesel Burner

Step	Bleeding the Diesel Burner
1	Place an oil pan under the machine in front of the burner.
2	Using a 3/8" wrench, loosen the bleeder valve on the fuel pump refer to Fig. 8.3 Diesel Burner Air Settings for bleeder location.
3	Turn the ignition key to the "ON" position, then turn the power toggle switch to the "ON" position. Fuel should flow out of the bleeder valve. You want the fuel to be clear from any air bubbles, this may require you to turn the ignition key "OFF" and "ON" a couple of times.
4	Allow burner to cycle itself off 30 seconds.
5	Tighten the bleeder valve.

Chapter 8 Illustrated Parts List

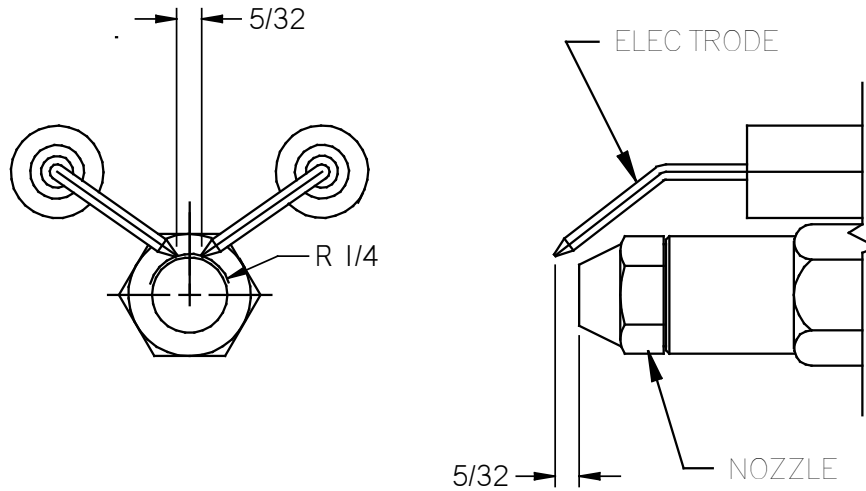

Fig. 8.2 Diesel Burner Electrode Adjustment

Air Shitter = 8
 Air Band = 2
 Fuel Pressure = 140 PSI
 Adjustment Plate = 3

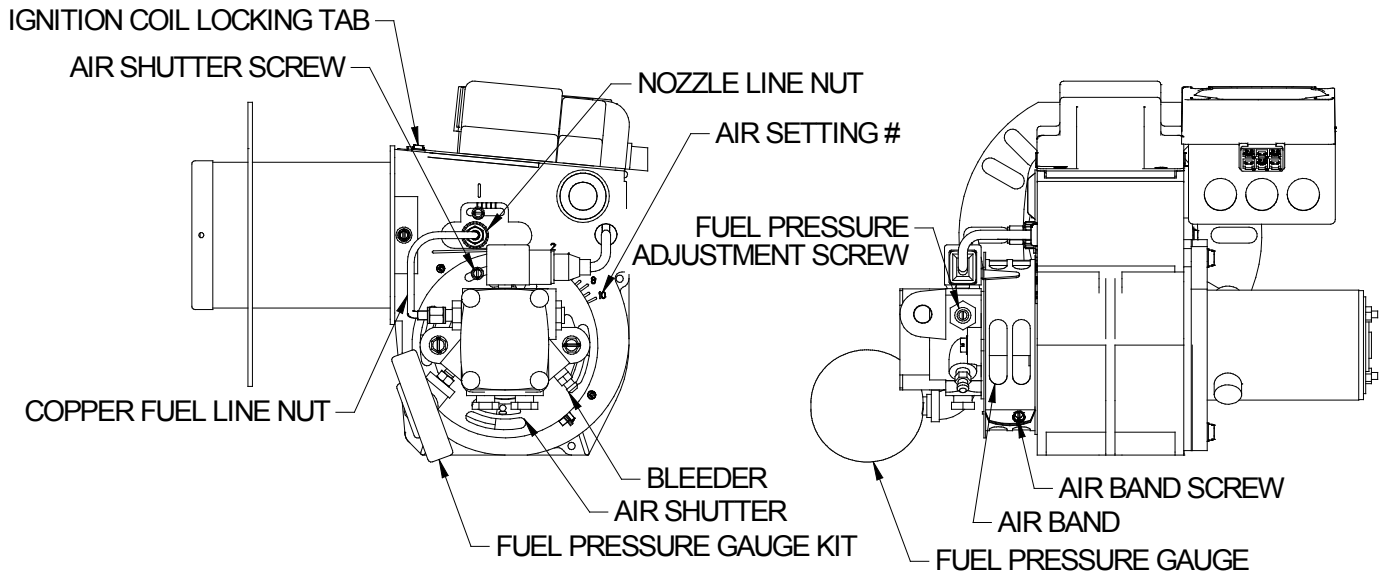

Fig. 8.3 Diesel Burner Air Settings

Chapter 8 Illustrated Parts List

8.1 Sealant is Heating Slowly

Table 8-13 Sealant is Heating Slowly

Step	Sealant is Heating Slowly
1	With the material level half or less, open the loading lid and inspect the inside edge of the material tank. Check if there is a buildup of old, dried out and hardened material along the top half of the material tank.
2	If this is the case you will need to drain out (use up) the rest of the material inside the tank. When the tank is empty, use an air chisel to remove this built up material. Remove as much as possible all around the tank including the roof of the material tank. Remove all the old sealant chunks from the bottom of the material tank. This should be done every year or as conditions require.
3	Check your level of the heat transfer oil, the mark on the dipstick is for 70°F.
4	Check your records of the last service replacement of the heat transfer oil. If it has been longer than 500 hours, or one year, you need to change your oil.
5	Many of Crafcoc, Inc. service centers can perform these service steps for you if you cannot. Call your local service center to find out if they can.

Chapter 8 Illustrated Parts List

8.2 Mixer Troubleshooting

8.2.1 Symptom: Mixer Does Not Rotate

Table 8-14 Basic Visual Mixer Troubleshooting

Step	Possible Cause	If . . .
1	Is the Material Temperature Display at or above 275°F?	<ul style="list-style-type: none"> • Yes, go to Step 2. • No, continue to allow the machine to heat. (Make sure the Material dial and the Hot Oil dial are set at operating temperatures.)
2	Is the red "Mixer" light "ON"?	<ul style="list-style-type: none"> • Yes, go to Step 4. No, go to Table 8-15 Mixer Electrical Troubleshooting
3	Is the loading door closed?	<ul style="list-style-type: none"> • Yes, go to Step 4. • No, shut the loading door.
4	Is the "Mixer" toggle switch in the "Forward" position?	<ul style="list-style-type: none"> • Yes, go to Step 5. • No, move the toggle switch to the forward position.
5	Move the "Mixer" toggle switch to the "Reverse" position. Is the agitator moving?	<ul style="list-style-type: none"> • Yes, allow mixer to reverse for 15 seconds and then move the "Mixer" toggle switch to the "Forward" position. Go to Step 6. No, go to Table 8-15 Mixer Electrical Troubleshooting
6	Open the Material loading door. Are there several unmelted blocks in the tank?	<ul style="list-style-type: none"> • Yes, this may cause the agitator to jam. Use the mixer toggle switch to move the agitator forward and backward until the material melts enough to allow forward movement without jamming. Crafco, Inc. recommends you add one to two blocks every three to four minutes during dispensing of product. • No, go to Table 8-15 Mixer Electrical Troubleshooting
7	Is the hydraulic fluid level near the center of the sight gauge? Check at ambient temperature. See Fig. 5.1 Hydraulic Fluid Level and Temp. Gauge	Yes, go to Table 8-15 Mixer Electrical Troubleshooting <ul style="list-style-type: none"> • No, fill oil to the center of the sight gauge.

Chapter 8 Illustrated Parts List

Note: Use Fig. 8.5 Mixer Circuit while troubleshooting the mixer electrical system.

Table 8-15 Mixer Electrical Troubleshooting

Step	Possible Cause	If . . .
1	Is the amber light "ON" on the Din Plug when the "Mixer" toggle switch is in the "Forward" position? (For forward din plug location. Refer to Fig. 8.7 P.S. Hydraulic Valve Din Plug Layout).	<ul style="list-style-type: none"> • Yes, then the mixer should be working. If it is not working see Table 8-18 Mixer Hydraulic Troubleshooting. • No, go to step 1a.
1a	Unscrew the din plug center screw so you can pull the din plug up about 1/4" in order to check for voltage. Is there 12Vdc from side post to side post?	<ul style="list-style-type: none"> • Yes, the electrical system for the agitator is working properly, go to Table 8-18 Mixer Hydraulic Troubleshooting. Also replace din plug at earliest convenience to retain visual troubleshooting ability. • No, go to step 2.
2	Is there 12Vdc between the "Mixer" toggle switch bottom post brown wire and nearby ground wire (black wire)? (With the "Mixer" toggle switch in the "Forward" position.)	<ul style="list-style-type: none"> • Yes, replace din plug. • No, go to Step 2a.
2a	Is there 12Vdc between the "Mixer" toggle switch center post red wire and nearby ground source (black wire)?	<ul style="list-style-type: none"> • Yes, replace mixer toggle switch • No, go to step 2b.
2b	Is there 12Vdc at the lower terminal block red wire labeled Red-8 and Red Lid P.S.?	<p>Yes to both then check for loose connections or broken wires between terminal block and mixer switch.</p> <p>Yes to Red Lid P.S. and No to Red-8 replace terminal block.</p> <p>No, go to step 3.</p>
3	Is there 12Vdc between the P.S. lid switch red wires and a nearby ground source? (Check both red wires on the bottom of the lid switch with the lid closed.)	<ul style="list-style-type: none"> • Yes, on both red wires check for loose connections or broken wires between lid switch and terminal block. • Yes, on only one red wire when the lid is closed. Readjust the lid switch so that the lid completely depresses the switch, and then recheck for 12Vdc. If the same result happens, replace the lid switch. • No, go to step 3a.

Chapter 8 Illustrated Parts List

Table 8-16 Mixer Electrical Troubleshooting (continued)

Step	Possible Cause	If . . .
3a	<p>Is there 12Vdc between the D.S. lid switch red wires and a nearby ground source? (Check both red wires on the bottom of the lid switch with the lid closed.)</p>	<ul style="list-style-type: none"> • Yes, on both red wires check for loose connections or broken wires between D.S. lid switch and P.S. lid switch. • Yes, on only one red wire when the lid is closed. Readjust the lid switch so that the lid completely depresses the switch, and then recheck for 12Vdc. If the same result happens, replace the lid switch. • No, go to step 4.
4	<p>Check for 12Vdc at red wire labeled Red Lid D.S. and pink wire labeled Pink-2 on terminal block and a nearby ground source (black wire).</p>	<ul style="list-style-type: none"> • Yes on both, check for loose connections or broken wires between D.S. lid switch and terminal block. • No on Red Lid D.S. and Yes on Pink-2, ensure yellow jumper bar is securely installed between the two terminal blocks. • No, go to step 4a.
4a	<p>Is there 12Vdc between the Material PAKSTAT terminal #2 pink wire and terminal #8 black ground wire?</p>	<ul style="list-style-type: none"> • Yes, check for loose connections or broken wires between PAKSTAT terminal #2 and terminal block. • No, go to Step 4b
4b	<p>Is there 12Vdc between the Material PAKSTAT terminal #1 orange wire and terminal #8 black ground wire?</p>	<ul style="list-style-type: none"> • Yes, replace the Material PAKSTAT. • No, go to Step 4c.
4c	<p>Is there 12Vdc between orange wire labeled ORN-1, terminal #9 and terminal #8 ground source (black wire)?</p>	<ul style="list-style-type: none"> • Yes, check for loose connections or broken wires between terminals #8 and #1. • No, go to step 5.
5	<p>Is there 12Vdc at orange wire labeled ORN-1 and ORN-2 on the upper terminal block?</p>	<ul style="list-style-type: none"> • Yes on both, check for loose connections or broken wires between terminal block and material PAKSTAT. • Yes on ORN-2 and No on ORN-1 replace terminal block. • No on both, go to step 6.
6	<p>Is there 12Vdc between orange wire labeled ORN-2 terminal #3 and terminal #5 black ground of hot oil PAKSTAT?</p>	<ul style="list-style-type: none"> • Yes, check for loose connections or broken wires between terminal #3 and terminal block. • No, go to step 7.

Chapter 8 Illustrated Parts List

Table 8-17 Mixer Electrical Troubleshooting (continued)

Step	Possible Cause	If . . .
7	Is there 12Vdc between top terminal of the power switch and a nearby ground (black wire)?	<ul style="list-style-type: none"> • Yes, check for loose connections or broken wires between toggle switch and hot oil PAKSTAT terminal #3. • No, go to step 7a.
7a	Is there 12Vdc between bottom terminal wire labeled RED-3 and a nearby ground source (black wire)?	<ul style="list-style-type: none"> • Yes, replace toggle switch. • No, go to step 8.
8	Is there 12Vdc between the top terminal of circuit breaker red wire labeled RED-3 and nearby ground source (black wire)?	<ul style="list-style-type: none"> • Yes, check for loose connections or broken wires between circuit breaker and toggle switch. • No, go to step 8a.
8a	Is there 12Vdc between the bottom terminal of circuit breaker red wire labeled RED-2 and nearby ground source (black wire)?	<ul style="list-style-type: none"> • Yes, replace circuit breaker • No, go to step 9.
9	Is there 12Vdc between ignition switch “ACC” terminal and nearby ground source (black wire)?	<ul style="list-style-type: none"> • Yes, check for loose connections or broken wires between “ACC” terminal and circuit breaker. • No, go to Step 9a.
9a	Is there 12Vdc between “B” (blue wire) of ignition switch and nearby ground source (black wire)?	<ul style="list-style-type: none"> • Yes, replace ignition switch. • No, go to Step 10.
10	Is there 12Vdc between blue wire on starter solenoid and nearby ground source (black wire or bare metal on engine case)?	<ul style="list-style-type: none"> • Yes, check for loose or broken wire between starter solenoid and ignition switch. • No, go to step 10a.
10a	Check connections and condition of red battery cable?	<ul style="list-style-type: none"> • Yes, there should be 12Vdc at all previous steps. • No, replace battery cable.

Chapter 8 Illustrated Parts List



Fig. 8.4 Checking Din Plug Voltage

Chapter 8 Illustrated Parts List

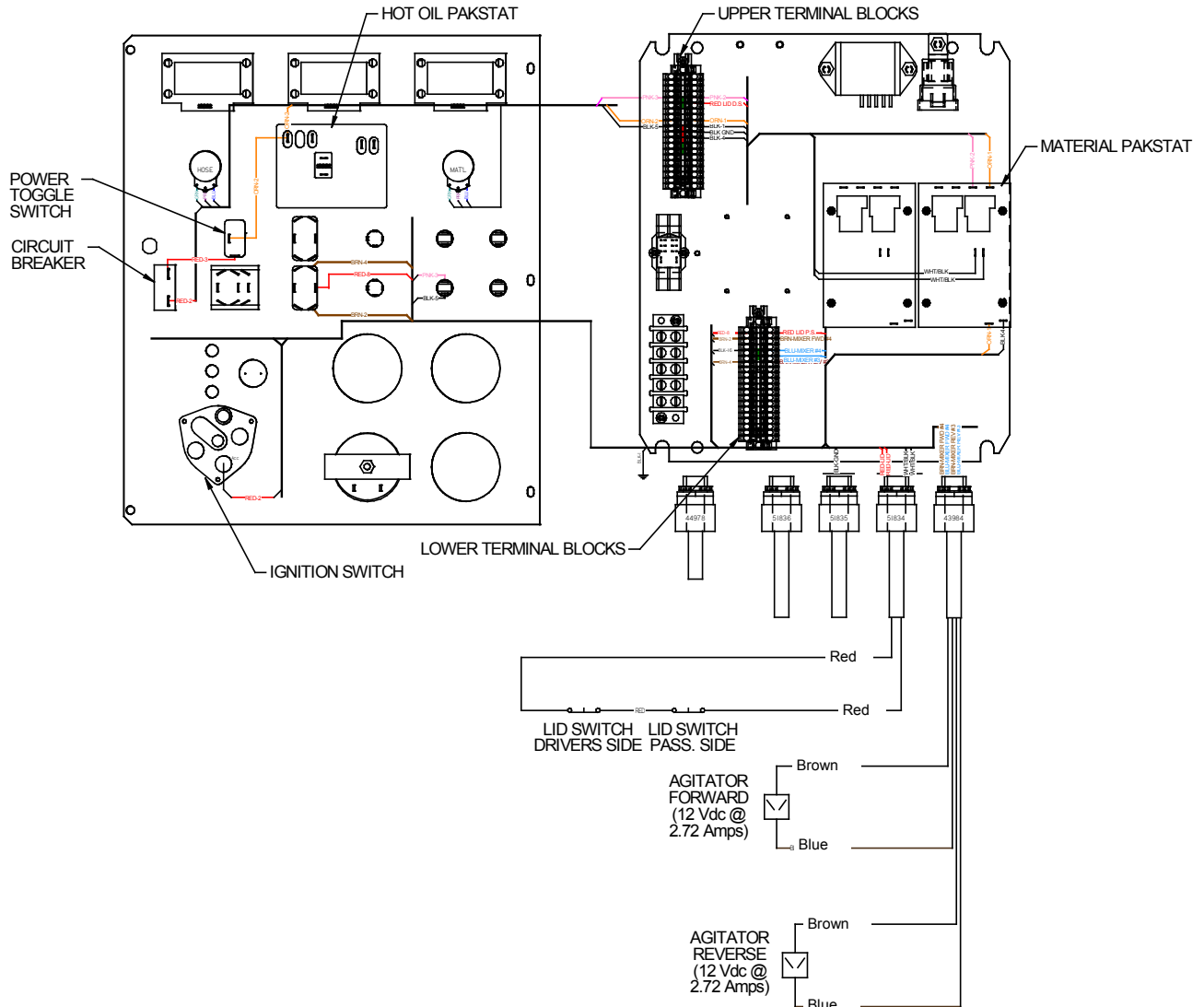

Fig. 8.5 Mixer Circuit

Chapter 8 Illustrated Parts List

8.2.2 Mixer Hydraulic Troubleshooting

Table 8-18 Mixer Hydraulic Troubleshooting

Step	Possible Cause	If . . .
1	Remove the din plug, then remove the coil by unscrewing the nut on top of the coil. With the coil removed, re-attach the din plug and energize the coil by moving the mixer switch to Forward or Reverse, then insert a screw driver into the center of the coil. Does the coil magnetize when the din plug amber light is "ON"?	<ul style="list-style-type: none"> • Yes, go to Step 2. • No, replace the coil.
2	Is the relief pressure set correctly? (Refer to Fig. 8.6 P.S. Hydraulic Valve Pressure Setting , for pressure settings.)	<ul style="list-style-type: none"> • Yes, go to Step 3. • No, first turn "OFF" the Isuzu engine, then remove one of the two hydraulic hoses going to the agitator hydraulic motor, cap off the fitting on the motor and use a 3,000 PSI gauge with the proper JIC fitting, attach it to the hose. Start the Isuzu engine, turn "ON" the main power in the control box, move the "Mixer" toggle switch to the "Forward" position and read the pressure gauge. If the pressure needs to be adjusted use the pressure relief valve labeled "RVA", loosen the jam nut and adjust the pressure with the allen screw at the end of the relief. Turn clockwise to increase pressure and counter clockwise to decrease pressure, then tighten the jam nut to lock the pressure. Next turn "OFF" the Isuzu engine, remove the cap and pressure gauge, then re-attach the hose.
3	Is the hydraulic flow 1.5 GPM from the hydraulic valve? If you do not have a flow meter, call a local hydraulic shop to run the test for you.	<ul style="list-style-type: none"> • Yes, call Crafco, Inc. and speak to a customer service technician, you should have been able to find the problem. • No, replace the flow divider in the hydraulic valve.
4	Is the hydraulic flow correct from the hydraulic pump? If you do not have a flow meter, call a local hydraulic shop to run the test for you. (Refer to Fig. 8.6 P.S. Hydraulic Valve Pressure Setting for flow rate).	<ul style="list-style-type: none"> • Yes, call Crafco, Inc. and speak to a customer service technician, you should have been able to find the problem. • No, replace the hydraulic pump.

Chapter 8 Illustrated Parts List

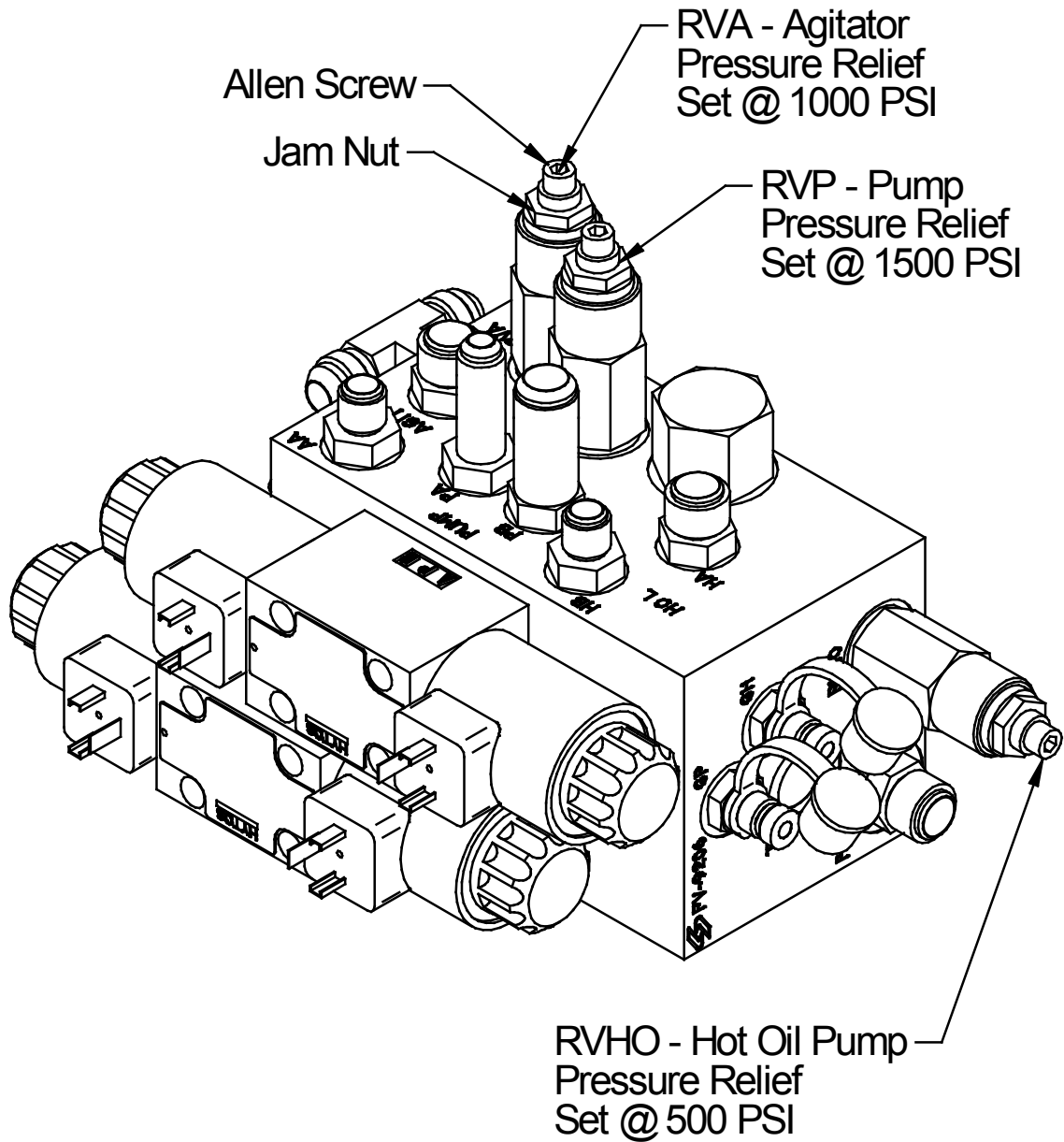

Agitation Direction = Counterclockwise
Hydraulic Pump Flow P.S. EB/SB= 10.8 GPM @ 2400 RPM

Fig. 8.6 P.S. Hydraulic Valve Pressure Setting

Chapter 8 Illustrated Parts List

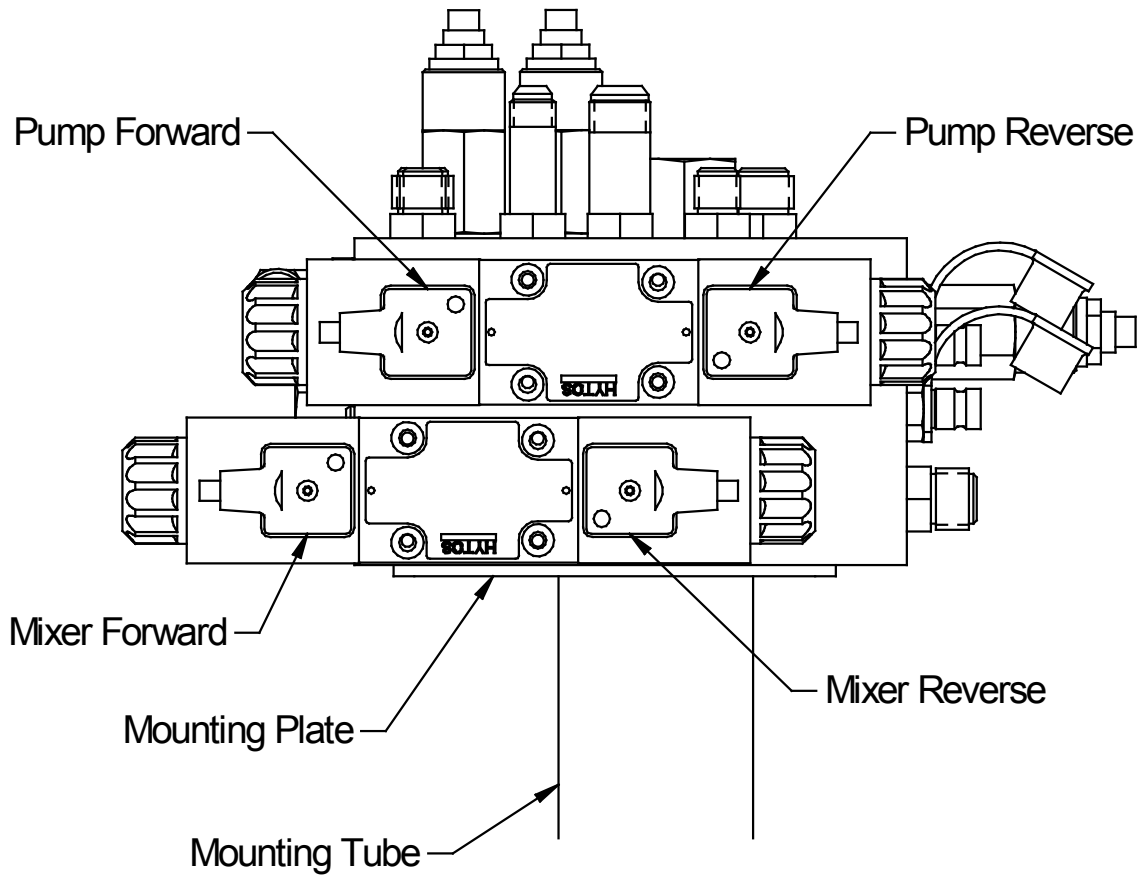

Fig. 8.7 P.S. Hydraulic Valve Din Plug Layout

Chapter 8 Illustrated Parts List

8.3 Hose Troubleshooting

8.3.1 Symptom: Hose Does Not Heat

Table 8-19 Basic Visual Hose Troubleshooting

Step	Possible Cause	If . . .
1	Is the Material Temperature Display at or above 275°F?	<ul style="list-style-type: none"> • Yes, go to Step 2. • No, continue to allow the machine to heat. (Make sure the Material dial and the Hot Oil dial are set at operating temperatures.)
2	Is the red "HEATED HOSE" light "ON"?	<ul style="list-style-type: none"> • Yes, go to Table 8-20 Hose Electrical Troubleshooting • No, allow the machine to heat material to 275°F.
2a	Is the circuit breaker tripped?	<ul style="list-style-type: none"> • Yes, reset the circuit breaker by pushing in the button which has popped out. • No, go to Table 8-20 Hose Electrical Troubleshooting

NOTE: Use [Fig. 8.9 Hose Circuit Schematic](#) while troubleshooting the hose electrical system.

Table 8-20 Hose Electrical Troubleshooting

Step	Possible Cause	If . . .
1	Is there 12Vdc between "BATT" terminal of the generator and a nearby ground source (lug on battery tray)?	<ul style="list-style-type: none"> • Yes, go to Step 2. • No, go to Step 6.
2	Is there 24Vac between the white, green, and black wires? NOTE: Do this test inside the junction box. Check between black and white, black and green, and green and white.	<ul style="list-style-type: none"> • Yes, go to Step 3 • No, stop the engine, tighten the belt, restart engine and recheck output voltage. • Still no, replace the generator.
2a	Check the three heating element wires (blue) in the junction box for 30 Amps cold or 20-22 Amps hot. NOTE: Always use a clamp-on amp meter to perform this test. Each wire should have the same amp reading (+/- 1 amp).	<ul style="list-style-type: none"> • Yes, the hose should be working properly. • No, go to Step 3.

Chapter 8 Illustrated Parts List

Table 8-21 Hose Electrical Troubleshooting (continued)

Step	Possible Cause	If . . .
3	<p>Check for continuity in the hose from end to end. Disconnect the three blue heating element wires (blue) from the terminal block inside the junction box and disconnect the five pin plug between the hose and wand. Refer to Fig. 8.10 Junction Box Wiring.</p> <p>NOTE: Check each letter “D”, “E”, and “A” with the three blue wires on the other end of the hose. There should only be continuity on one wire to each letter.</p>	<ul style="list-style-type: none"> • Yes, go to Step 3a. • No, either there was no continuity from one letter to the other end of the hose or there was more than one wire with continuity to a letter. This hose needs to be repaired or replaced. Contact Crafcoc, Inc. to send back the hose for repair.
3a	<p>Check the RTD sensor in the hose against the readout in the control box. Disconnect the black and white wires from the terminal block in the junction box and test for ohms.</p> <p>Refer to Table 8-24 RTD Sensor Ohms vs. Temperature</p>	<ul style="list-style-type: none"> • Yes, the readout matches the table, go to Step 4. • No, this hose needs to be repaired or replaced. Contact Crafcoc, Inc. to send back the hose for repair.
4	<p>Check for continuity in the wand between “D”, “E”, and “A”.</p> <p>NOTE: Check between “D” and “E”, “D” and “A”, and “A” and “E”.</p>	<ul style="list-style-type: none"> • Yes, go to Step 5. • No, this wand needs to be repaired or replaced. Contact Crafcoc, Inc. to send back the wand for repair.
5	<p>Is there 12Vdc between wire labeled “BLU-GEN” on the upper terminal block and nearby ground source (black wire)?</p>	<ul style="list-style-type: none"> • Yes, check for loose or broken connections between terminal block “BATT” terminal of generator. • No, go to Step 6.
6	<p>Is there 12Vdc between Hose PAKSTAT blue wire terminal #4 and black wire terminal #8?</p>	<ul style="list-style-type: none"> • Yes, check for loose or broken wire between terminal #4 and the terminal block. • No, go to Step 6a.
6a	<p>Is there 12Vdc between Hose PAKSTAT terminal #3 Pink wire and terminal #8 black wire?</p>	<ul style="list-style-type: none"> • Yes, replace hose PAKSTAT. • No, go to Step 6b.
6b	<p>Is there 12Vdc between Hose PAKSTAT pink wire terminal #1 and black wire terminal #8?</p>	<ul style="list-style-type: none"> • Yes, check for loose or broken wires between terminal #1 and terminal #3. • No, go to Step 7.
7	<p>Is there 12Vdc between pink wire labeled “PNK-1 on the upper terminal block and a nearby ground source (black wire)?</p>	<ul style="list-style-type: none"> • Yes, check for loose or broken wire between terminal block and terminal #1. • No go to Step 7.
7a	<p>Is there 12Vdc between pink wire labeled “PNK-4 and nearby ground source (black wire)?</p>	<ul style="list-style-type: none"> • Yes, replace terminal block. • No, go to Step 8.

Chapter 8 Illustrated Parts List

Table 8-22 Hose Electrical Troubleshooting (continued)

Step	Possible Cause	If . . .
8	Is there 12Vdc between the Hose Selector switch pink wire labeled "PNK-4 (bottom left terminal) and a near" ground source black wire?	<ul style="list-style-type: none"> • Yes, check for loose or broken wires between switch and upper terminal block. • No, go to Step 8a.
8a	Is there 12Vdc between the Hose Selector switch pink wire Labeled "PNK-3" center left terminal and a nearby ground source.	<ul style="list-style-type: none"> • Yes, replace Hose Selector switch. • No, go to Step 9.
9	Is there 12Vdc between pink wire labeled "PNK-3" on the upper terminal block and a nearby ground source black wire?	<ul style="list-style-type: none"> • Yes, check for loose or broken wire between terminal block and hose selector switch. • No go to Step 9a.
9a	Is there 12Vdc between pink wire labeled "PNK-2" on upper terminal block and nearby ground source black wire?	<ul style="list-style-type: none"> • Yes, replace terminal block. • No, go to Table 8-16 Mixer Electrical Troubleshooting (continued) Steps 4a through 10a.

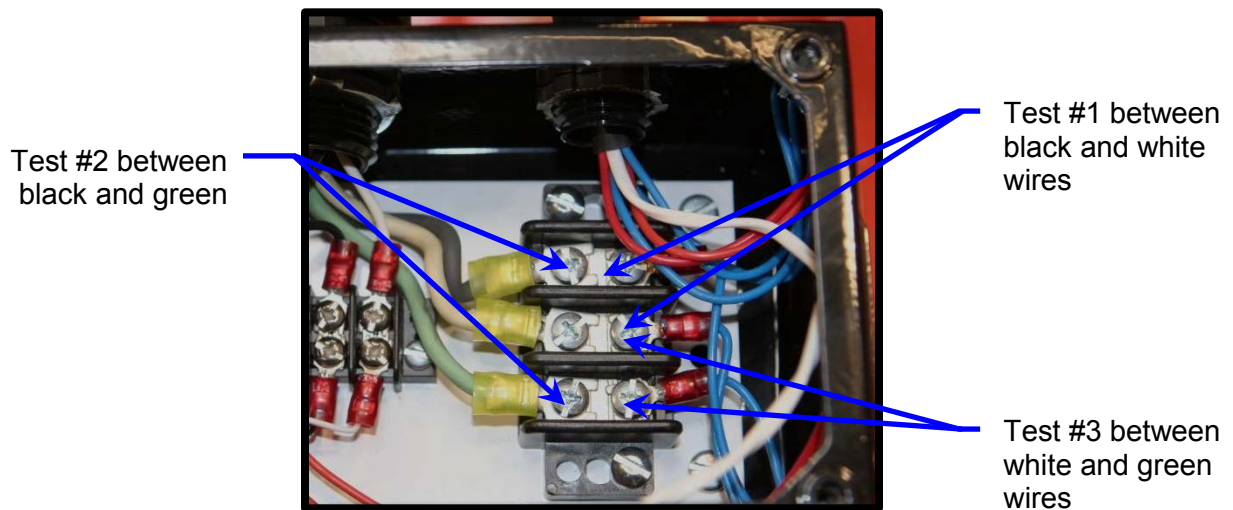

Fig. 8.8 Junction Box Voltage Testing

Chapter 8 Illustrated Parts List

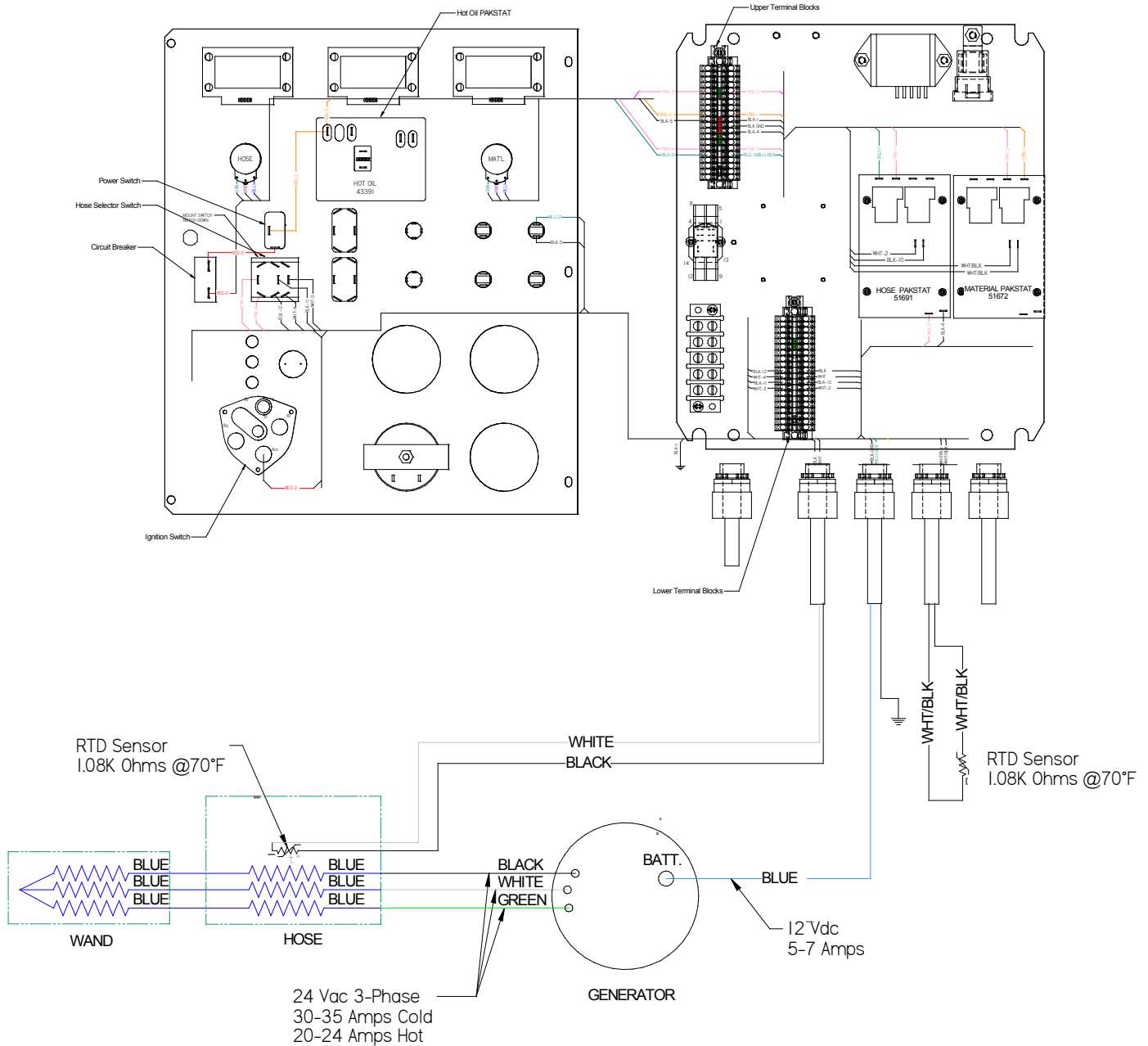

Fig. 8.9 Hose Circuit Schematic

Chapter 8 Illustrated Parts List

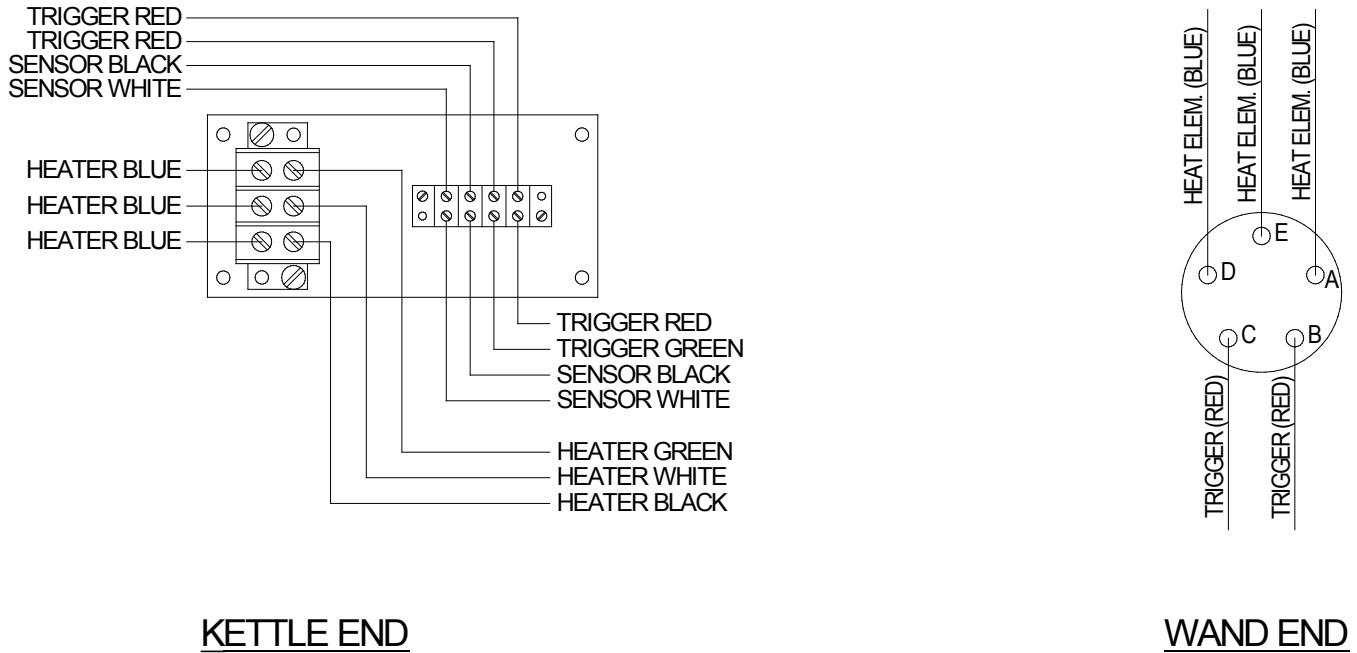

Fig. 8.10 Junction Box Wiring

Chapter 8 Illustrated Parts List

8.3.2 Symptom: Trigger is not working

Table 8-23 Trigger is Not Working

Step	Possible Cause	If . . .
1	<p>Check continuity between two red wires coming from the hose in junction box.</p> <p>NOTE: These wires must be disconnected from the terminal block and the trigger depressed to perform this test.</p>	<ul style="list-style-type: none"> • Yes, go to Table 8-26 Basic Visual P.S. Pump Troubleshooting or Table 8-31 Basic Visual D.S. Pump Troubleshooting • No, go to Step 2.
2	<p>Disconnect the electrical connector between the hose and wand, check for continuity between C and B wand side.</p>	<ul style="list-style-type: none"> • Yes, this hose needs to be repaired or replaced. Contact Crafcoc, Inc. to send back the hose for repair. • No, this wand needs to be repaired or replaced. Contact Crafcoc, Inc. to send back the hose for repair.

Chapter 8 Illustrated Parts List

8.3.3 RTD Sensor Ohms vs. Temperature

Table 8-23 below shows what the ohm reading would be for a given temperature. The following are the instructions for using the table.

Measure the resistance (ohms) of the sensor in question with an ohm meter See [7.3 Checking Resistance \(Ohms\)](#) in [7.0 How to Use a Multimeter](#).

Find the reading in the chart (columns 0 through 9).

Follow the row to the left and get the temperature in 10°F increments, then follow the column up to get the 1°F increment. (For example, 1391 Ohms = 215°F)

Table 8-24 RTD Sensor Ohms vs. Temperature

°F	0	1	2	3	4	5	6	7	8	9
0	930.3	932.5	934.7	936.9	939.1	941.3	943.4	945.6	947.8	950.0
10	952.2	954.3	956.5	958.7	960.9	963.0	965.2	967.4	969.6	971.8
20	973.9	976.1	978.3	980.5	982.6	984.8	987.0	989.1	991.3	993.5
30	995.7	997.8	1000.0	1002.2	1004.3	1006.5	1008.7	1010.9	1013.0	1015.2
40	1017.4	1019.5	1021.7	1023.9	1026.0	1028.2	1030.4	1032.5	1034.7	1036.9
50	1039.0	1041.2	1043.4	1045.5	1047.7	1049.8	1052.0	1054.2	1056.3	1058.5
60	1060.7	1062.8	1065.0	1067.1	1069.3	1071.5	1073.6	1075.8	1077.9	1080.1
70	1082.2	1084.4	1086.6	1088.7	1090.9	1093.0	1095.2	1097.3	1099.5	1101.6
80	1103.8	1106.0	1108.1	1110.3	1112.4	1114.6	1116.7	1118.9	1121.0	1123.2
90	1125.3	1127.5	1129.6	1131.8	1133.9	1136.1	1138.2	1140.4	1142.5	1144.7
100	1146.8	1149.0	1151.1	1153.2	1155.4	1157.5	1159.7	1161.8	1164.0	1166.1
110	1168.3	1170.4	1172.5	1174.7	1176.9	1179.0	1181.1	1183.3	1185.4	1187.5
120	1189.7	1191.8	1194.0	1196.1	1198.2	1200.4	1202.5	1204.6	1206.8	1208.9
130	1211.0	1213.2	1215.3	1217.5	1219.6	1221.7	1223.9	1226.0	1228.1	1230.3
140	1232.4	1234.5	1236.7	1238.9	1240.9	1243.0	1245.2	1247.3	1249.4	1251.6
150	1253.7	1255.8	1258.0	1260.1	1262.2	1264.3	1266.5	1268.6	1270.7	1272.8
160	1275.0	1277.1	1279.2	1281.3	1283.5	1285.6	1287.7	1289.8	1292.0	1294.1
170	1296.2	1298.3	1300.4	1302.6	1304.7	1306.8	1308.9	1311.0	1313.2	1315.3
180	1317.4	1319.5	1321.6	1323.8	1325.9	1328.0	1330.1	1332.2	1334.3	1336.5
190	1338.6	1340.7	1342.8	1344.9	1347.0	1349.1	1351.2	1353.4	1355.5	1357.6
200	1359.7	1361.8	1363.9	1366.0	1368.1	1370.2	1372.4	1374.5	1376.6	1378.7
210	1380.8	1382.9	1385.0	1387.1	1389.2	1391.3	1393.4	1395.5	1397.6	1399.7
220	1401.8	1403.9	1406.0	1408.1	1410.3	1412.4	1414.5	1416.6	1418.7	1420.8
230	1422.9	1425.0	1427.1	1429.2	1431.3	1433.4	1435.5	1437.6	1439.6	1441.7
240	1443.8	1445.9	1448.0	1450.1	1452.2	1454.3	1456.4	1458.5	1460.6	1462.7
250	1464.8	1466.9	1469.0	1471.1	1473.2	1475.3	1477.3	1479.4	1481.5	1483.6
260	1485.7	1487.8	1489.9	1492.0	1494.1	1496.1	1498.2	1500.3	1502.4	1504.5

Chapter 8 Illustrated Parts List

Table 8-25 RTD Sensor Ohms vs. Temperature (continued)

°F	0	1	2	3	4	5	6	7	8	9
270	1506.6	1508.7	1510.8	1512.8	1514.9	1517.0	1519.1	1521.2	1523.3	1525.3
280	1527.4	1529.5	1531.6	1533.7	1535.7	1537.8	1539.9	1542.0	1544.1	1546.1
290	1548.2	1550.3	1552.4	1554.5	1556.5	1558.6	1560.7	1562.8	1564.8	1566.9
300	1569.0	1571.1	1573.1	1575.2	1577.3	1579.4	1581.4	1583.5	1585.6	1587.7
310	1589.7	1591.8	1593.9	1595.9	1598.0	1600.1	1602.2	1604.2	1606.3	1608.4
320	1610.4	1612.5	1614.6	1616.6	1618.7	1620.8	1622.8	1624.9	1627.0	1629.0
330	1631.1	1633.2	1635.2	1637.3	1639.3	1641.4	1643.5	1645.5	1647.6	1649.7
340	1651.7	1653.8	1655.8	1657.9	1660.0	1662.0	1664.1	1666.1	1668.2	1670.2
350	1672.3	1674.4	1676.4	1678.5	1680.5	1682.6	1684.6	1686.7	1688.7	1690.8
360	1692.9	1694.9	1697.0	1699.0	1701.1	1703.1	1705.2	1707.2	1709.3	1711.3
370	1713.4	1715.4	1717.5	1719.5	1721.6	1723.6	1725.7	1727.7	1729.8	1731.8
380	1733.9	1735.9	1737.9	1740.0	1742.0	1744.1	1746.1	1748.2	1750.2	1752.3
390	1754.3	1756.3	1758.4	1760.4	1762.5	1764.5	1766.6	1768.6	1770.6	1772.7
400	1774.7	1776.8	1778.8	1780.8	1782.9	1784.9	1786.9	1789.0	1791.0	1793.1
410	1795.1	1797.1	1799.2	1801.2	1803.2	1805.3	1807.3	1809.3	1811.4	1813.4
420	1815.4	1817.5	1819.5	1821.5	1823.6	1825.6	1827.6	1829.6	1831.7	1833.7
430	1835.7	1837.8	1839.8	1841.8	1843.8	1845.9	1847.9	1849.9	1851.9	1854.0
440	1856.0	1858.0	1860.0	1862.1	1864.1	1866.1	1868.1	1870.2	1872.2	1874.2
450	1876.2	1878.2	1880.3	1882.3	1884.3	1886.3	1888.3	1890.4	1892.4	1894.4
460	1896.4	1898.4	1900.5	1902.5	1904.5	1906.5	1908.5	1910.5	1912.6	1914.6
470	1916.6	1918.6	1920.6	1922.6	1924.6	1926.6	1928.7	1930.7	1932.7	1934.7
480	1936.7	1938.7	1940.7	1942.7	1944.7	1946.8	1948.8	1950.8	1952.8	1954.8
490	1956.8	1958.8	1960.8	1962.8	1964.8	1966.8	1968.8	1970.8	1972.8	1974.8
500	1976.8	1978.8	1980.8	1982.9	1984.9	1986.9	1988.9	1990.9	1992.9	1994.9
510	1996.9	1998.9	2000.9	2002.9	2004.9	2006.9	2008.8	2010.8	2012.8	2014.8
520	2016.8	2018.8	2020.8	2022.8	2024.8	2026.8	2028.8	2030.8	2032.8	2034.8
530	2036.8	2038.8	2040.8	2042.8	2044.7	2046.7	2048.7	2050.7	2052.7	2054.7
540	2056.7	2058.7	2060.7	2062.7	2064.6	2066.6	2068.6	2070.6	2072.6	2074.6
550	2076.6	2078.5	2080.5	2082.5	2084.5	2086.5	2088.5	2090.4	2092.4	2094.4

Chapter 8 Illustrated Parts List

8.4 Pump Troubleshooting

8.4.1 Symptom: Material Does Not Dispense When the P.S. Pump is Activated

Table 8-26 Basic Visual P.S. Pump Troubleshooting

Step	Possible Cause	If . . .
1	Is the Hose Temperature Display at or above 325°F?	<ul style="list-style-type: none"> • Yes, go to Step 2. • No, continue to allow the hose to heat. (Make sure the Hose dial is set at proper operating temperature.)
2	Is the red "Pump" light "ON"?	<ul style="list-style-type: none"> • Yes, go to Step 3. • No, go to Table 8-27 P.S. Pump Electrical Troubleshooting.
3	Is the hose selector switch in the "ELECTRIC" position as well as the pump switch should be in "ON ELECTRIC" position?	<ul style="list-style-type: none"> • Yes, go to Step 4. • No, move the toggle switches to the proper positions.
4	With the wand in the shoebox, pull the wand trigger and look at the material pump shaft coupler. Is it spinning clockwise?	<ul style="list-style-type: none"> • Yes, shut down machine and look for a plug in the plumbing. • No, adjust the material flow control to increase the flow. • Still no, go to Step 5.
5	Inside the control box and under the front panel, find the relay cube for the pump. It is found near the middle, left-hand side of the box. It is a clear yellow cube with a green button facing the top of the control box. When the trigger is engaged does the green light illuminate?	<ul style="list-style-type: none"> • Yes, this indicates that 12Vdc is reaching the relay coil. Go to Table 8-28 P.S. Pump Electrical Troubleshooting (continued), Step 5 to find the problem. • No, go to Table 8-27 P.S. Pump Electrical Troubleshooting, Steps 2 to find the problem.
5	Is the hydraulic fluid level near the center of the sight gauge when the machine is cold? See Fig. 5.1 Hydraulic Fluid Level and Temp. Gauge	<ul style="list-style-type: none"> • Yes, go to Table 8-27 P.S. Pump Electrical Troubleshooting. • No, fill oil to the center of the sight gauge.

Chapter 8 Illustrated Parts List

NOTE: Use [Figure 8.12 P.S. Pump Circuit Schematic](#) while troubleshooting the pump electrical system.

Table 8-27 P.S. Pump Electrical Troubleshooting

Step	Possible Cause	If . . .
1	Is the amber light “ON” on the Din Plug when the trigger is actuated? For pump forward din plug location Refer to Fig. 8.7 P.S. Hydraulic Valve Din Plug Layout	<ul style="list-style-type: none"> • Yes, then the pump should be working. If it is not working see Table 8-35 Pump Hydraulic Troubleshooting • No, go to Step 1a.
1a	Unscrew the center screw of the din plug so you can pull the din plug up 1/4” in order to check voltage. Is there 12Vdc from side post to side post?	<ul style="list-style-type: none"> • Yes, the electrical system for the pump is working properly. Refer to Table 8-35 Pump Hydraulic Troubleshooting. • No, go to Step 4.
2	Is there 12Vdc between red wire labeled “TRIGGER RED” in junction box and nearby ground source?	<ul style="list-style-type: none"> • Yes, go to Step 2a. • No, go to Table 8-29 P.S. Pump Electrical Troubleshooting (continued) Step 10 for an Electric Hose. • No, for a Standard Hose is normal because this circuit is not used.
2a	Is there 12Vdc between green wire labeled “TRIGGER GRN” in junction box and nearby ground source? NOTE: Wand trigger must be actuated during this test.	<ul style="list-style-type: none"> • Yes, go to Step 3. • No, see Table 8-23 Trigger is Not Working.
3	Is there 12Vdc between green wire on terminal #14 of pump relay and black wire terminal #13 pump relay? NOTE: Wand trigger must be actuated during this test.	<ul style="list-style-type: none"> • Yes, go to Step 5. • No, check for loose or broken wire between relay and junction box.
4	Is there 12Vdc between the brown wire located on the lower set of terminal blocks, top right terminal and 5 th terminal down on the right blue ground wire? NOTE: Wand Trigger must be actuated or pump switch in “ON STANDARD” position during this test.	<ul style="list-style-type: none"> • Yes, replace Din Plug. • No, go to Step 4a.
4a	Is there 12Vdc between the blue wire located on the lower set of terminal blocks, top left terminal and 5 th terminal down on the left black ground wire? NOTE: Trigger must be actuated or pump switch in “ON STANDARD” position during this test.	<ul style="list-style-type: none"> • Yes, replace terminal block. • No, go to Step 5.

Chapter 8 Illustrated Parts List

Table 8-28 P.S. Pump Electrical Troubleshooting (continued)

Step	Possible Cause	If . . .
5	Is there 12Vdc between the blue wire on terminal #12 of pump relay and the black wire on terminal #13 of pump relay? NOTE: Trigger must be actuated or pump switch in “ON STANDARD” position during this test.	<ul style="list-style-type: none"> • Yes, check for loose or broken wire between terminal #12 and the terminal block. • No, go to Step 5a for Electric Hose. • No, go to Step 5b for Standard Hose.
5a	Is there 12Vdc on red wire terminal #8 of pump relay and black wire terminal #13?	<ul style="list-style-type: none"> • Yes, replace relay. • Go to Step 6
5b	Is there 12Vdc on red wire terminal #4 of pump relay and black wire terminal #13? NOTE: This only applies to “ON STANDARD” position of pump switch.	<ul style="list-style-type: none"> • Yes, replace relay. • No, go to Step 7.
6	Is there 12Vdc between red wire labeled RED-1 upper terminal block and a nearby ground source (black wire)?	<ul style="list-style-type: none"> • Yes, check for loose or broken wire between terminal block and terminal #8. • No, go to Step 6a.
6a	Is there 12Vdc between red wire labeled RED-4 upper terminal block and nearby ground source (black wire)?	<ul style="list-style-type: none"> • Yes, replace terminal block. • No, go to Table 8-17 Mixer Electrical Troubleshooting (continued) steps 9-10a.
7	Is there 12Vdc between red wire labeled RED-9 on top right hand terminal of pump switch and a nearby ground source?	<ul style="list-style-type: none"> • Yes, check for loose or broken wire between pump switch and pump relay. • No, go to Step 7a.
7a	Is there 12Vdc between purple wire labeled PRP-3 on center right hand terminal of pump switch and a nearby ground source (black wire)?	<ul style="list-style-type: none"> • Yes, replace pump switch. • No, go to Step 8.
8	Is there 12Vdc between purple wire labeled PRP-3 top left terminal of hose selector switch and nearby ground (black wire)?	<ul style="list-style-type: none"> • Yes, check for loose or broken wire between hose selector switch and pump switch. • No go to Step 8a.
8a	Is there 12Vdc between pink wire labeled PNK-3 center left terminal of hose selector switch and nearby ground (black wire)?	<ul style="list-style-type: none"> • Yes, replace hose selector switch. • No, go to Step 9.
9	Is there 12Vdc between pink wire labeled PNK-3 upper terminal block and nearby ground (black wire)?	<ul style="list-style-type: none"> • Yes, check for loose or broken wire between terminal block and hose selector switch. • No, go to Step 9a.

Chapter 8 Illustrated Parts List

Table 8-29 P.S. Pump Electrical Troubleshooting (continued)

Step	Possible Cause	If . . .
9a	Is there 12Vdc between pink wire labeled PNK-2 upper terminal block and nearby ground (black wire)?	<ul style="list-style-type: none"> • Yes, replace terminal block. • No, go to Table 8-16 Mixer Electrical Troubleshooting (continued) Steps 4a through 10a.
10	Is there 12Vdc between red wire labeled "RED-TRIG" upper terminal block and nearby ground source (black wire)?	<ul style="list-style-type: none"> • Yes, check for loose or broken wire between terminal block and junction box. • No, go to Step 11.
11	Is there 12Vdc between purple wire labeled "PRP-1" upper terminal block and nearby ground source (black wire)?	<ul style="list-style-type: none"> • Yes, ensure the yellow jumper in the middle of the terminal blocks connected to the "PRP-1" and "RED-TRIG" wires is push in all the way. • No, Go to Step 12
12	Is there 12Vdc between purple wire on terminal #2 of hose PAKSTAT and terminal #8 black ground wire?	<ul style="list-style-type: none"> • Yes, check for loose or broken wire between PAKSTAT and terminal block. NOTE: This wire has a diode that could be bad and cause an open circuit. • No, go to Step 12a.
12a	Is there 12Vdc between pink wire on terminal #1 of hose PAKSTAT and terminal #8 black ground wire?	<ul style="list-style-type: none"> • Yes, replace the hose PAKSTAT. • No, go to Step 13.
13	Is there 12Vdc between pink wire labeled "PNK-1" upper terminal blocks and nearby ground source (black wire)?	<ul style="list-style-type: none"> • Yes, check for loose or broken wire between terminal blocks and hose PAKSTAT. • No, go to Step 13a
13a	Is there 12Vdc between pink wire labeled "PNK-4" upper terminal blocks and nearby ground source (black wire)?	<ul style="list-style-type: none"> • Yes, replace terminal block. • No, go to Step 14.
14	Is there 12Vdc between pink wire labeled "PNK-4" lower left terminal of hose selector switch and nearby ground source (black wire)?	<ul style="list-style-type: none"> • Yes, check for loose or broken wire between hose selector switch and terminal block. • No, go to Step 14a.
14a	Is there 12Vdc between pink wire labeled "PNK-3" center left terminal of hose selector switch and nearby ground source (black wire)?	<ul style="list-style-type: none"> • Yes, replace hose selector switch. • No, go to Step 15.

Chapter 8 Illustrated Parts List

Table 8-30 P.S. Pump Electrical Troubleshooting (continued)

Step	Possible Cause	If ...
15	Is there 12Vdc between pink wire labeled "PNK-3" on the upper terminal block and a nearby ground source black wire?	<ul style="list-style-type: none"> • Yes, check for loose or broken wire between terminal block and hose selector switch. • No go to Step 9a.
15a	Is there 12Vdc between pink wire labeled "PNK-2" on upper terminal block and nearby ground source black wire?	<ul style="list-style-type: none"> • Yes, replace terminal block. • No, go to Table 8-16 Mixer Electrical Troubleshooting (continued) Steps 4a through 10a.

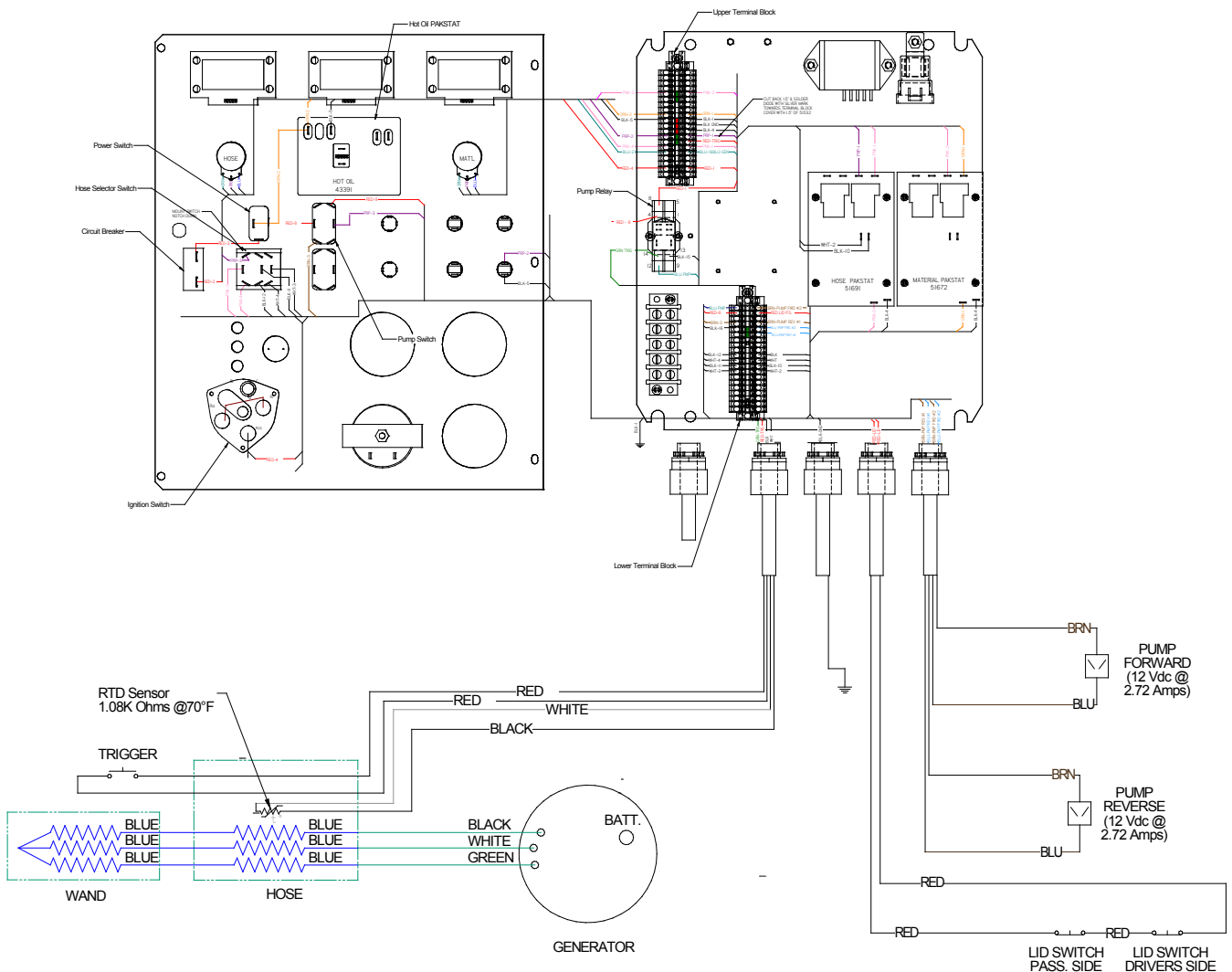

Fig. 8.11 P.S. Pump Circuit Schematic

Chapter 8 Illustrated Parts List

8.4.2 Symptom: Material Does Not Dispense When the D.S. Pump is Activated

Table 8-31 Basic Visual D.S. Pump Troubleshooting

Step	Possible Cause	If . . .
1	Is the Hose Temperature Display at or above 325°F?	<ul style="list-style-type: none"> • Yes, go to Step 2. • No, continue to allow the hose to heat. (Make sure the Hose dial is set at proper operating temperature.)
2	Is the red "Pump" light "ON"?	<ul style="list-style-type: none"> • Yes, go to Step 3. • No, go to Table 8-32 D.S. Pump Electrical Troubleshooting.
3	Is the hose selector switch in the "ELECTRIC" position as well as the pump switch should be in "ON ELECTRIC" position?	<ul style="list-style-type: none"> • Yes, go to Step 4. • No, move the toggle switches to the proper positions.
4	With the wand in the shoebox, pull the wand trigger and look at the material pump shaft coupler. Is it spinning clockwise?	<ul style="list-style-type: none"> • Yes, shut down machine and look for a plug in the plumbing. • No, adjust the material flow control to increase the flow. • Still no, go to Step 5.
5	Inside the control box and under the front panel, find the relay cube for the pump. It is found near the middle, left-hand side of the box. It is a clear yellow cube with a green button facing the top of the control box. When the trigger is engaged does the green light illuminate?	<ul style="list-style-type: none"> • Yes, this indicates that 12Vdc is reaching the relay coil. Go to Table 8-32 D.S. Pump Electrical Troubleshooting, Steps 3 through 9a to find the problem. • No, go to Table 8-32 D.S. Pump Electrical Troubleshooting, Step 4.
5	Is the hydraulic fluid level near the center of the sight gauge when the machine is cold? See Fig. 5.1 Hydraulic Fluid Level and Temp. Gauge	<ul style="list-style-type: none"> • Yes, go to Table 8-32 D.S. Pump Electrical Troubleshooting. • No, fill oil to the center of the sight gauge.

Chapter 8 Illustrated Parts List

NOTE: Use Fig. 8.12 D.S. Pump Circuit Schematic while troubleshooting the pump electrical system.

Table 8-32 D.S. Pump Electrical Troubleshooting

Step	Possible Cause	If . . .
1	Is the amber light “ON” on the Din Plug when the trigger is actuated? For pump forward din plug location Refer to Fig. 8.13 D.S. Hydraulic Valve Din Plug Layout	<ul style="list-style-type: none"> • Yes, then the pump should be working. If it is not working see Table 8-35 Pump Hydraulic Troubleshooting • No, go to Step 1a.
1a	Unscrew the center screw of the din plug so you can pull the din plug up 1/4” in order to check voltage. Is there 12Vdc from side post to side post?	<ul style="list-style-type: none"> • Yes, the electrical system for the pump is working properly. Refer to Table 8-35 Pump Hydraulic Troubleshooting. • No, go to Step 2.
2	Is there 12Vdc between red wire labeled “TRIGGER RED” in junction box and nearby ground source (black wire)?	<ul style="list-style-type: none"> • Yes, go to Step 2a. • No, go to Table 8-34 D.S. Pump Electrical Troubleshooting (continued) Step 12 for an Electric Hose. • No, for a Standard Hose is normal because this circuit is not used.
2a	Is there 12Vdc between green wire labeled “TRIGGER GRN” in junction box and nearby ground source (black wire)? NOTE: Wand trigger must be actuated during this test.	<ul style="list-style-type: none"> • Yes, go to Step 3. • No, see Table 8-20 Hose Electrical Troubleshooting steps 10 through XX
3	Is there 12Vdc between green wire on terminal #14 of pump relay and black wire terminal #13 pump relay? NOTE: Wand trigger must be actuated during this test.	<ul style="list-style-type: none"> • Yes, go to Step 4. • No, check for loose or broken wire between relay and junction box.
4	Is there 12Vdc between the brown wire located on the pump relay, bottom left terminal and black wire terminal #13? NOTE: Wand Trigger must be actuated or pump switch in “ON STANDARD” position during this test.	<ul style="list-style-type: none"> • Yes, replace Din Plug. • No, go to Step 4a Electric Hose. • No, go to Step 4b Standard Hose.
4a	Is there 12Vdc on red wire terminal #8 of pump relay and black wire terminal #13?	<ul style="list-style-type: none"> • Yes, replace relay. • Go to Step 6
4b	Is there 12Vdc on red wire terminal #4 of pump relay and black wire terminal #13? NOTE: This only applies to “ON STANDARD” position of pump switch.	<ul style="list-style-type: none"> • Yes, replace relay. • No, go to Steps 9 – 10a for standard hose pump issues.

Chapter 8 Illustrated Parts List

Table 8-33 D.S. Pump Electrical Troubleshooting (continued)

Step	Possible Cause	If . . .
6	Is there 12Vdc between red wire labeled "RED-4" power relay terminal #8 and a nearby ground source (black wire)?	<ul style="list-style-type: none"> • Yes, replace relay. • No, go to Step 6a.
6a	Is there 12Vdc between red wire labeled "RED-POWER" on pump relay bottom left terminal #12 and nearby ground source (black wire)?	<ul style="list-style-type: none"> • Yes, check for loose or broken wire between power relay and terminal block. • No, go to Table 8-17 Mixer Electrical Troubleshooting (continued) steps 9-10a.
7	Is there 12Vdc between red wire labeled "RED-POWER" on circuit breaker located under battery box and nearby ground Source (black wire)?	<ul style="list-style-type: none"> • Yes, check for loose or broken wire between circuit breaker and power relay. • No, go to 7a
7a	Is there 12Vdc between the circuit breaker (red wire going to battery positive cable) and the ground lug on the battery tray?	<ul style="list-style-type: none"> • Yes, wait 15 seconds then repeat step 7. • If still no voltage then replace circuit breaker. • No, go to step 7b.
7b	Check for loose or broken wires between circuit breaker and battery positive cable.	<ul style="list-style-type: none"> • Yes, replace or repair damaged wire and repeat Step 7a. • No, go to step 8.
8	Is there 12Vdc between the positive and negative battery post? If this check is done while the engine is running the reading should 13.8 volts.	<ul style="list-style-type: none"> • Yes, then there should be 12Vdc on the battery side of the circuit breaker. • No, replace battery. • Note: If the reading is less than 13.8 volts while the engine is running the alternator needs to be rebuilt or replaced.
9	Is there 12Vdc between red wire labeled RED-9 on top right hand terminal of pump switch and a nearby ground source? NOTE: Pump switch must be in the "ON STANDARD" position of pump switch.	<ul style="list-style-type: none"> • Yes, check for loose or broken wire between pump switch and pump relay. • No, go to Step 9a.
9a	Is there 12Vdc between purple wire labeled PRP-3 on center right hand terminal of pump switch and a nearby ground source (black wire)?	<ul style="list-style-type: none"> • Yes, replace pump switch. • No, go to Step 10.
10	Is there 12Vdc between purple wire labeled PRP-3 top left terminal of hose selector switch and nearby ground (black wire)? NOTE: Hose selector switch must be in "STANDARD" position.	<ul style="list-style-type: none"> • Yes, check for loose or broken wire between hose selector switch and pump switch. • No go to Step 10a.

Chapter 8 Illustrated Parts List

Table 8-34 D.S. Pump Electrical Troubleshooting (continued)

Step	Possible Cause	If . . .
10a	Is there 12Vdc between yellow wire labeled "YLW-2" center left terminal of hose selector switch and nearby ground source (black wire)?	<ul style="list-style-type: none"> • Yes, replace hose selector switch. • No, go to Step 11.
11	Is there 12Vdc between yellow wire labeled "YLW-2" on top terminal power switch and nearby ground source (black wire)?	<ul style="list-style-type: none"> • Yes, check for loose or broken wire between power switch and hose selector switch. • No, go to Step 11a.
11a	Is there 12Vdc between yellow wire labeled "YLW-3" bottom terminal of power switch and nearby ground (black wire)?	<ul style="list-style-type: none"> • Yes, replace power switch. • No, go to Step 12.
12	Is there 12Vdc between yellow wire labeled "YLW-3" bottom terminal of circuit breaker and nearby ground source (black wire)?	<ul style="list-style-type: none"> • Yes, check for loose or broken wire between circuit breaker and power switch. • No, go to Step 12a.
12a	Is there 12Vdc between red wire labeled "RED-3" top terminal of circuit breaker and nearby ground source (black wire)?	<ul style="list-style-type: none"> • Yes, replace circuit breaker • No, Go to Step 13
13	Is there 12Vdc between red wire labeled "RED-3" on terminal blocks and nearby ground source (black wire)?	<ul style="list-style-type: none"> • Yes, check for loose or broken wire between terminal block and circuit breaker. • No, go to Step 13a.
13a	Is there 12Vdc between red wire labeled "RED-2" on terminal blocks and nearby ground source (black wire)?	<ul style="list-style-type: none"> • Yes, replace the terminal block. • No, go to Steps 6 - 8. Or call Crafco, Inc. and speak to a customer service technician, you should have been able to find the problem.

Chapter 8 Illustrated Parts List

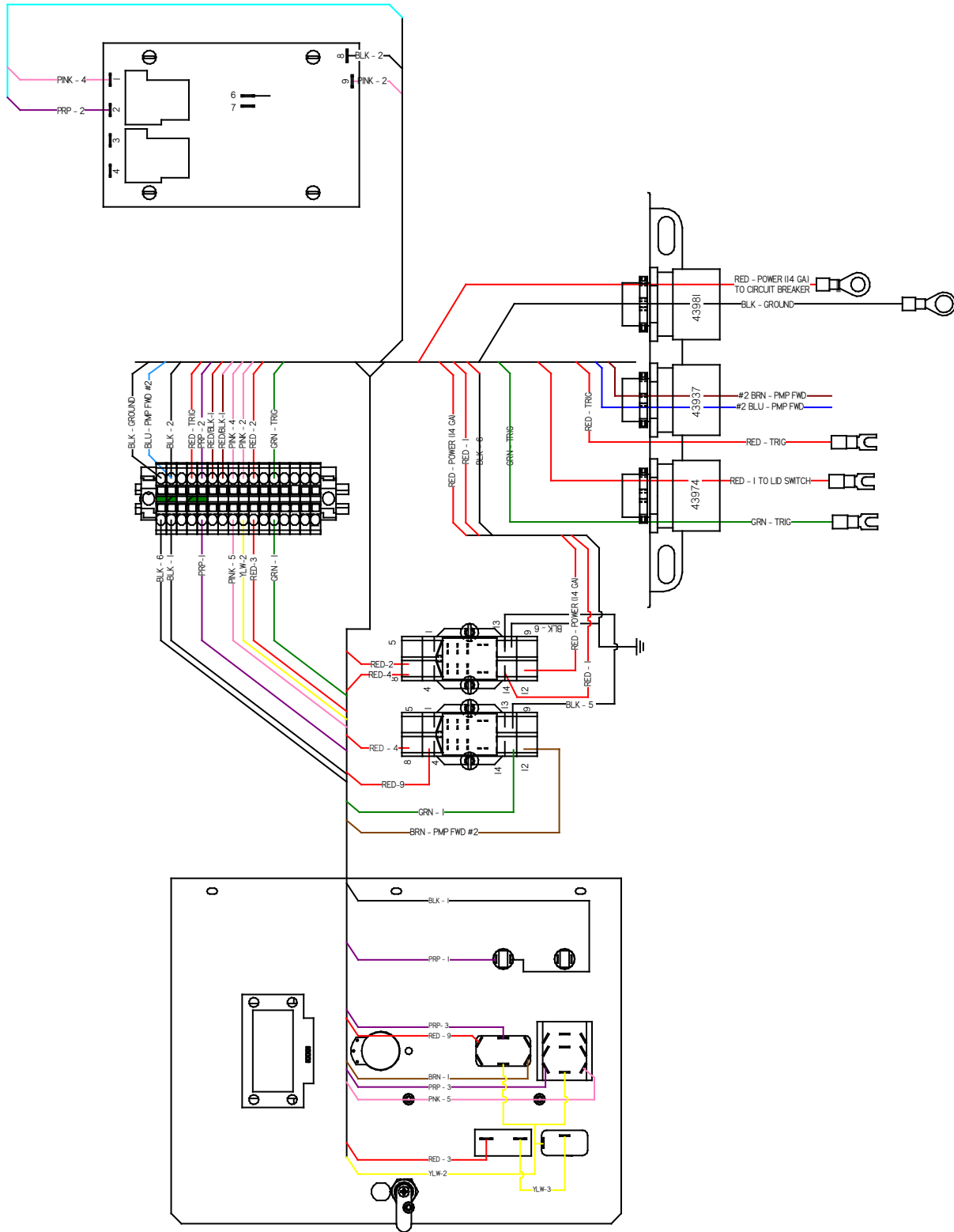

Fig. 8.12 D.S. Pump Circuit Schematic

Chapter 8 Illustrated Parts List

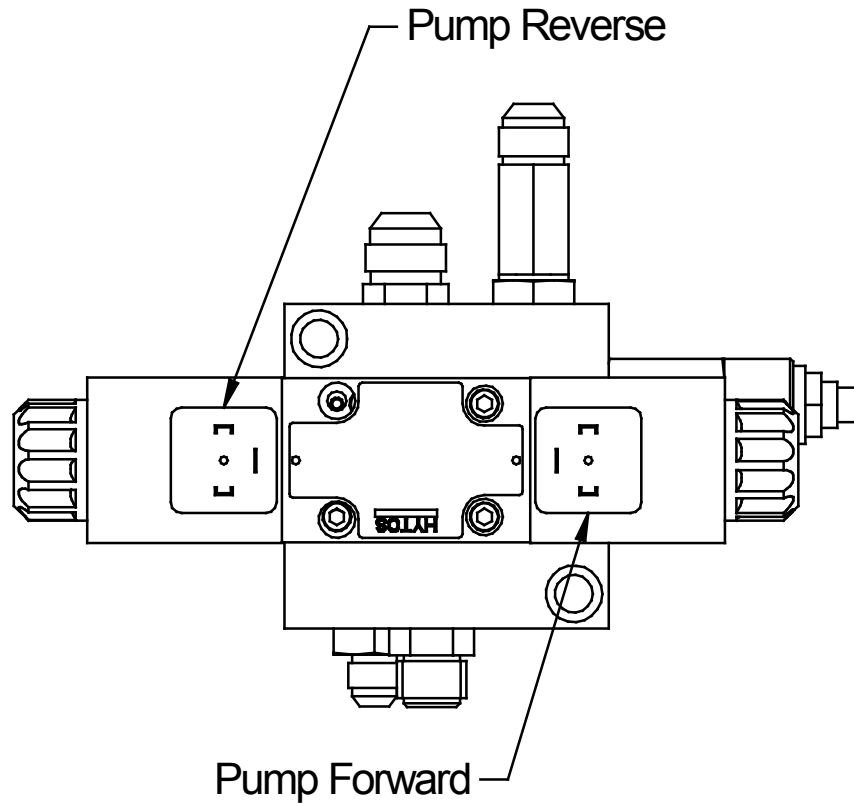

Fig. 8.13 D.S. Hydraulic Valve Din Plug Layout

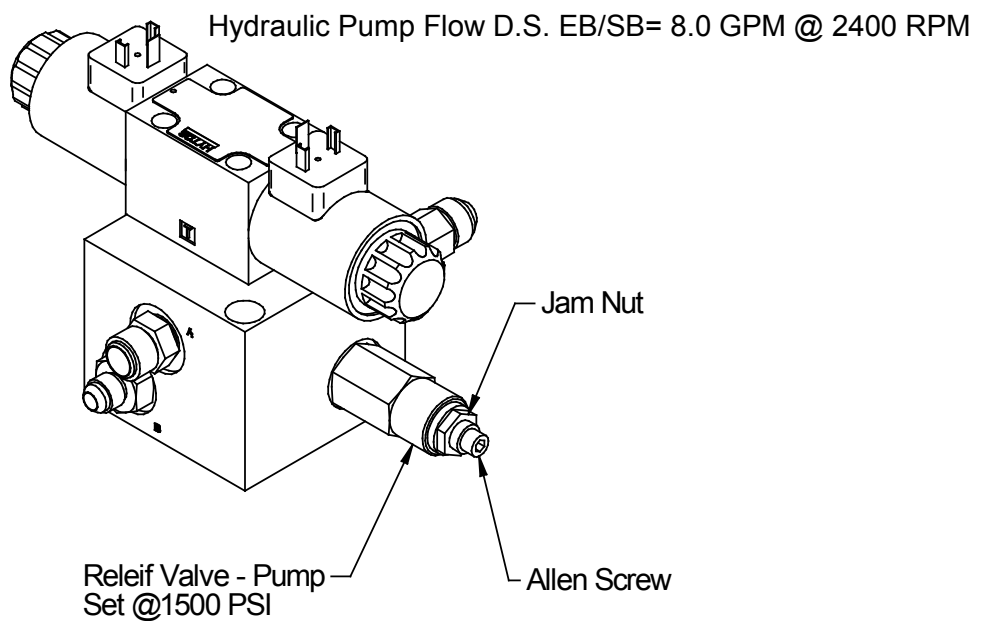

Fig. 8.14 D.S. Hydraulic Valve Pressure Setting

Chapter 8 Illustrated Parts List

Table 8-35 Pump Hydraulic Troubleshooting

Step	Possible Cause	If...
1	Does the coil magnetize when the din plug amber light is "ON"?	<ul style="list-style-type: none"> • Yes, go to Step 2. • No, remove the din plug, then remove the coil by unscrewing the nut on the end of the coil. With the coil removed reattach the din plug and place a metal screw driver in the center of the coil to see if the coil is magnetic. If it is not, recheck the din plug is plugged into the coil and the amber light is "ON". If still not magnetic replace the coil.
2	Is the relief pressure set correctly? (Refer to Fig. 8.6 P.S. Hydraulic Valve Pressure Setting).	<ul style="list-style-type: none"> • Yes, go to Step 3. • No, first turn "OFF" the Isuzu engine, then remove one of the two hydraulic hoses going to the pump hydraulic motor, cap off the fitting on the motor and use a 3000 PSI gauge with the proper JIC fitting, attach it to the hose. Start the Isuzu engine, turn "ON" the main power in the control box, pull the wand trigger and read the pressure gauge. If the pressure needs to be adjusted use the pressure relief valve marked "RVP", loosen the jam nut and adjust the pressure with the allen screw at the end of the relief. Turn clockwise to increase pressure and counter clockwise to decrease pressure, then tighten the jam nut to lock pressure. Next turn "OFF" the Isuzu engine, remove the cap, pressure gauge and reattach the hose.
3	Is the hydraulic flow correct from the hydraulic pump? (Refer to Fig. 8.6 P.S. Hydraulic Valve Pressure Setting).	<ul style="list-style-type: none"> • Yes, call Crafco, Inc. and speak to a service technician, you should have been able to find the problem. • No, call a local hydraulic shop to see if they can run a hydraulic pump flow test, using the information in Fig. 8.6 P.S. Hydraulic Valve Pressure Setting.

Chapter 8 Illustrated Parts List

9.0 About the Illustrated Parts List

The Illustrated Parts List (IPL) is designed to help technical service or maintenance personnel correctly identify orderable replacement parts.

The figure and table titles reference the part number (PN) to which they apply. The PN's for each of the EZ 1500 Series II Diesel Melter machine models are as follows:

EZ1500 Series II Electric Base Diesel Melter PN46500EB

EZ1500 Series II Standard Base Diesel Melter PN46500SB

Illustrations are designed to show general shape and size of a part and the relationship that part has to other parts. Actual size and shape of parts or components may differ or vary from the actual part or component.

9.1 Ordering Crafco Parts

Crafco distributors and Crafco Pavement Preservation Supply Centers are strategically located throughout the United States. Parts can be ordered from your local Crafco distributor or directly from Crafco, Inc. if a distributor is not available in your area.

When ordering parts, give the following information:

- Part Number
- Machine Model
- Serial Number

Write, call, or Fax Crafco, Inc. at the following:

Crafco, Inc. Headquarters

420 N. Roosevelt Ave.

Chandler, AZ 85226-2601

Phone: (602) 276-0406

Toll Free: (800) 528-8242

Fax: (480) 961-0513

Visit our website at www.crafco.com

Chapter 8 Illustrated Parts List

9.2 EZ1500 Series II Double Pumper Parts List

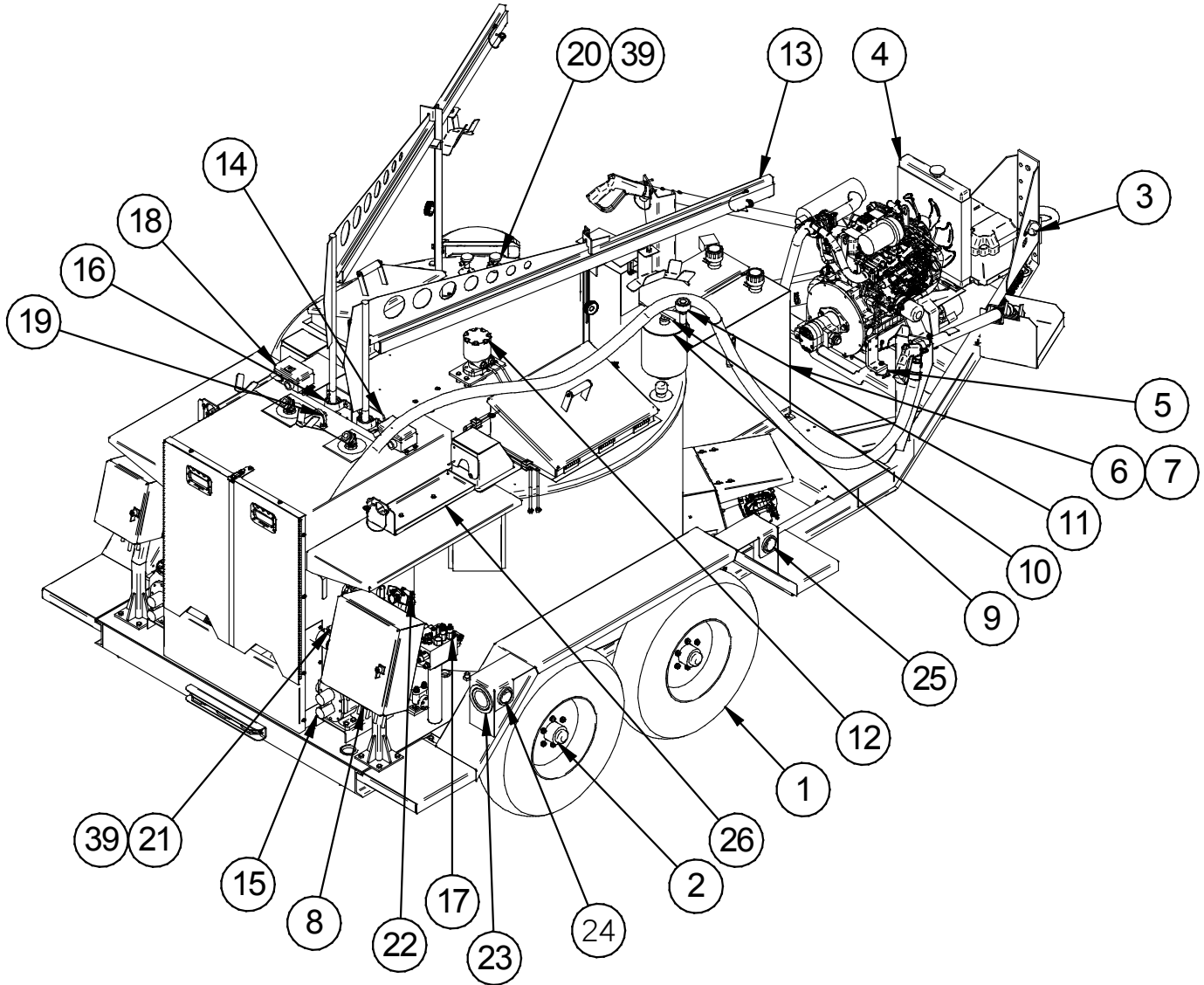

Fig. 9.1 EZ1500 Series II Double Pumper Melter

Chapter 8 Illustrated Parts List

FIG.	ITEM	PART NO.	DESCRIPTION	QTY.
Fig. 9.1	1	90100	TIRE AND WHEEL ASSEMBLY	4
	2	45704	TORSIONAL AXLE ASSEMBLY	2
	3	23117	BREAKAWAY SWITCH	1
	4	46718	ENGINE ASSEMBLY – 46500EB	1
	4	46727	ENGINE ASSEMBLY – 46500SB	1
	5	29399	ISOMOUNT	4
	6	46255	HYDRAULIC TANK ASSEMBLY	1
	7	45498	HYDRAULIC FILTER ASSEMBLY	1
	7a	45438	HYDRAULIC FILTER ELEMENT	1
	7b	45440	O-RING, HYDRAULIC FILTER	1
	7c	45497	GASKET, HYDRAULIC FILTER	1
	7d	45437	GAUGE, HYDRAULIC FILTER	1
	8	46620	CONTROL BOX ASSY., P.S. – EB	1
	8	46715	CONTROL BOX ASSY., P.S. – SB	1
	9	43355	OVERFLOW TANK	1
	10	46450	DIPSTICK	1
	11	26025	AIR BREATHER	1
	12	45706	MOTOR, HYDRAULIC – AGITATOR	1
	13	46010	BOOM, PASSENGER SIDE – HOSE	1
	14	45579	BASE, BOOM	1
	15	43127	MATERIAL PUMP ASSEMBLY, P.S.	1
	16	45553	BEARING, BOOM	2
	17	45433	HYDRAULIC CONTROL VALVE ASSEMBLY, P.S.	1
	18	44027	JUNCTION BOX ASSEMBLY	2
	19	25057	GAUGE, HOSE COMPARTMENT	1
	20	43465	SENSOR, RTD	2
21	56940	SENSOR, RTD – PUMPING TEMPERATURE	2	
22	46060	REGULATOR, FLOW	2	
23	32363	TAIL LIGHT, STOP, TURN, AND TAIL	2	
24	32364	SIDE MARKER, RED	2	
25	44796	CLEARANCE MARKER, YELLOW	4	
26	46707	SUPPORT ASSEMBLY, P.S. WAND	1	

Chapter 8 Illustrated Parts List

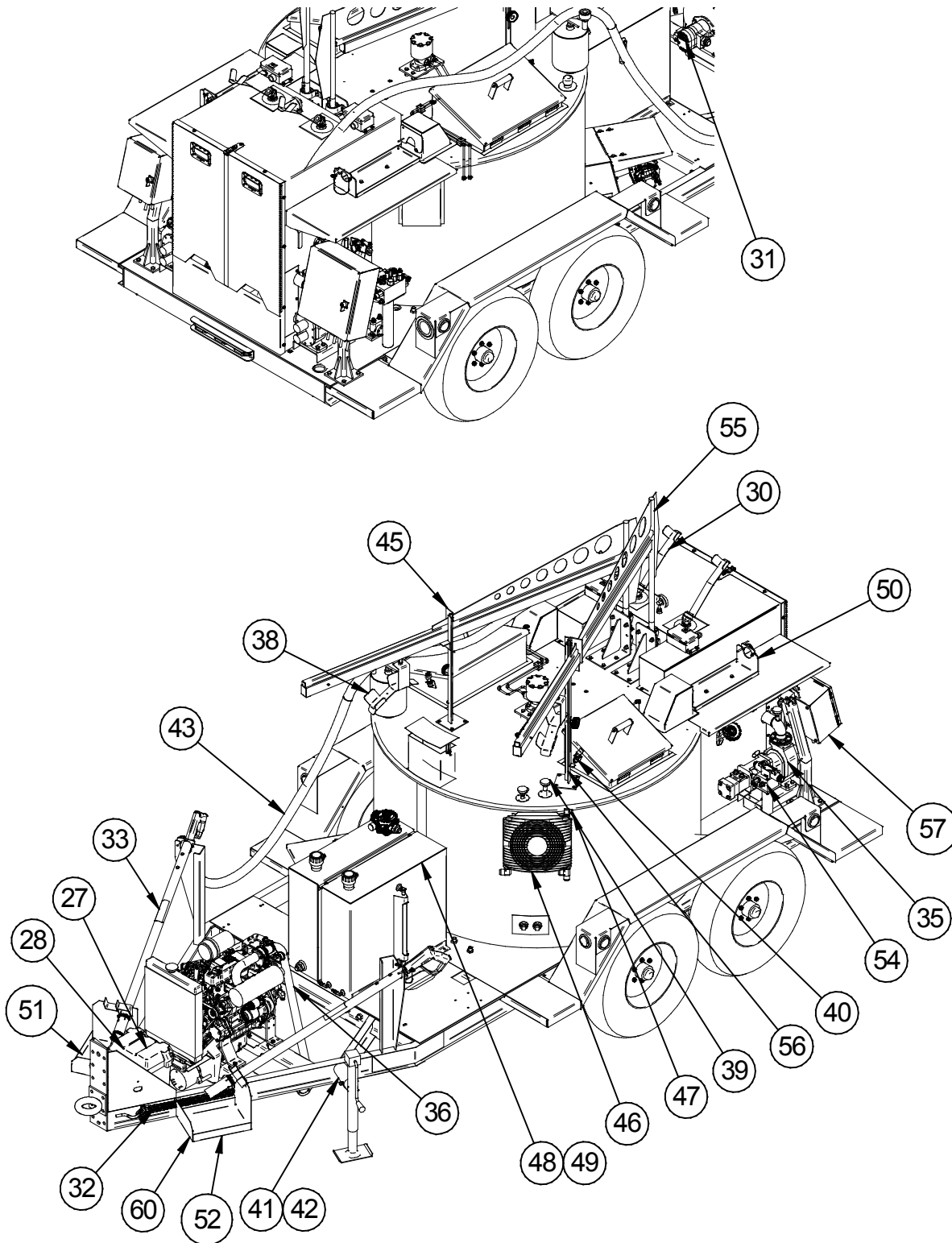

Fig. 9.2 EZ1500 Series II Double Pumper Melter

Chapter 8 Illustrated Parts List

FIG.	ITEM	PART NO.	DESCRIPTION	QTY.
Fig. 9.2	27	24000	BATTERY	1
	28	24002	BATTERY BOX	1
	29	27048	SWIVEL, STANDARD HOSE (Not Shown)	OPT.
	30	46340	SUPPORT, ELECTRIC HOSE	1
	31	45446	HYDRAULIC PUMP ASSEMBLY – EB/SB	1
	32	20130	SAFETY CHAIN	2
	32	46572	FENDER ASSEMBLY	2
	33	51730	WAND ASSEMBLY – ELECTRIC	OPT.
	34	46129	WAND – STANDARD HOSE (Not Shown)	OPT.
	35	41208	HANDLE W/ VALVE, STANDARD (Not Shown)	OPT.
	36	45372	EXHAUST PIPE – SB	1
	36	46338	EXHAUST PIPE – EB	1
	37	44785	NOZZLE, BURNER (Not Shown)	1
	38	46053	HOSE HANGER	2
	39	51065	CORD GRIP	4
	40	39608	SWITCH, LID	2
	41	23095	BUSHING, JACK ASSEMBLY	1
	42	23082	JACK ASSEMBLY, 7000#	1
	43	51731	ELECTRIC HEATED HOSE ASSEMBLY, 15'	OPT.
	44	27009	HOSE, 20' SEALANT (Not Shown)	OPT.
	45	46263	BOOM LOCK ASSEMBLY, P.S.	1
	46	45762	HYDRAULIC OIL COOLER	1
	47	45542	TEMPERATURE SWITCH, COOLER	1
	48	46250	DIESEL FUEL TANK ASSEMBLY	1
	49	44191	TUBING, SIGHT GLASS	1.75 ft.
	50	46747	SUPPORT ASSEMBLY, D.S. WAND	1
	51	46041	DRIP PAN, P.S.	1
	52	46580	DRIP PAN, D.S.	1
	53	46710	CONTROL BOX ASSY., D.S. – EB	1
	53	46720	CONTROL BOX ASSY., D.S. – SB	1
54	45445	HYDRAULIC VALVE ASSY., D.S. PUMP	1	

Chapter 8 Illustrated Parts List

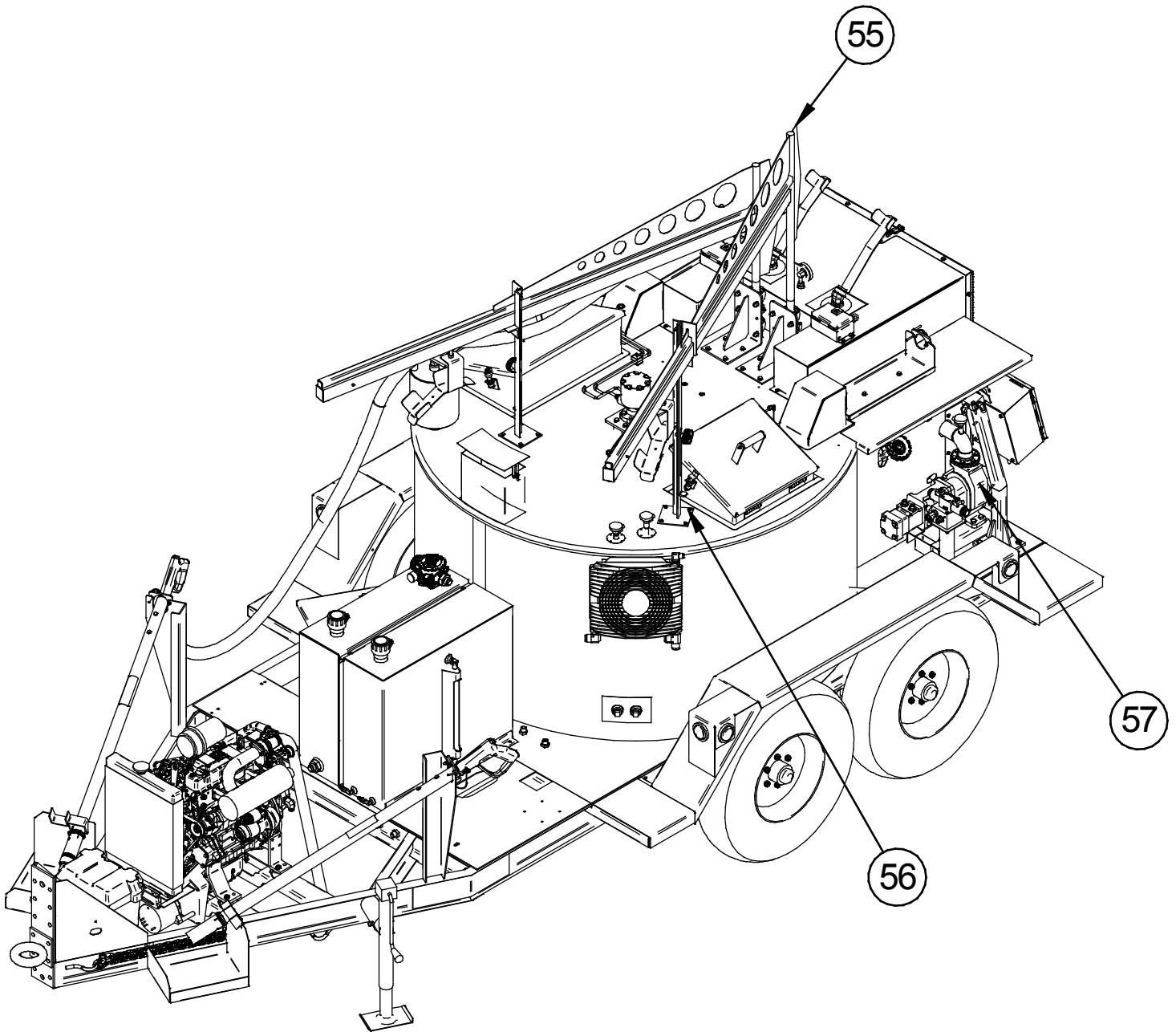

Fig. 9.3 EZ1500 Series II Double Pumper Melter

Chapter 8 Illustrated Parts List

FIG.	ITEM	PART NO.	DESCRIPTION	QTY.
Fig. 9.3	55	46632	BOOM ASSY, D.S.	1
	56	46742	BOOM LOCK ASSEMBLY, D.S.	1
	57	43126	MATERIAL PUMP ASSEMBLY, D.S.	1

Chapter 8 Illustrated Parts List

9.3 Machine Options

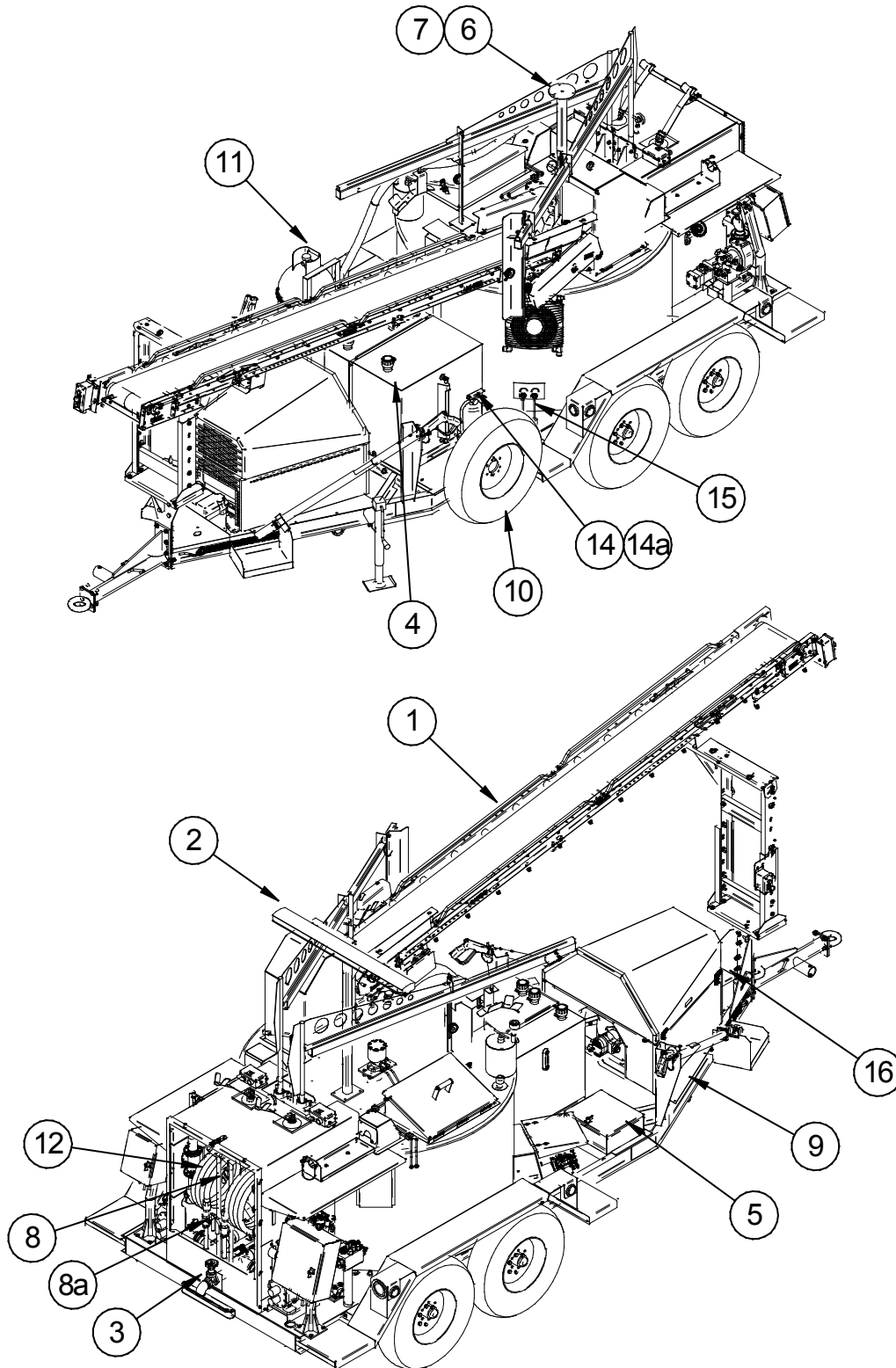

Fig. 9.4 EZ1500 Series II Melter Options

Chapter 8 Illustrated Parts List

FIG.	ITEM	PART NO.	DESCRIPTION	QTY.
Fig. 9.4	1	51390	CONVEYOR ASSEMBLY	1
	1a	46614	BOOM LOCK, CONVEYOR	1
	2	46726K	ARROW BOARD	1
	3	41930	KIT, GRAVITY FEED	1
	4	47000	FUEL TANK, 60 GALLON	1
	5	46260	TOOL BOX	1
	6	46170K	STROBE LIGHT KIT	1
	7	46160K	LIGHT BAR KIT	1
	8	41629	HAND WAND ASSEMBLY	2
	8a	41208	HANDLE ASSEMBLY W/ VALVE	2
	9	45535	ENGINE COVER ASSEMBLY	1
	9a	44151	SUPPORT, ENGINE COVER	2
	10	42743	KIT, SPARE TIRE	1
	11	41259K	KIT, 100# PROPANE TANK	1
	12	27009	20' SEALANT HOSE	2
	13	26119	3/8" SAFETY HOOK (NOT SHOWN)	2
	14	26058	FIRE EXTINGUISHER W/ COVER	1
	14a	26059	BRACKET, FIRE EXTINGUISHER	1
15	24190	HEATER, FIREROD	2	
16	24086	BATTERY BOX, LOCKABLE	1	
17	27048†	SWIVEL, STANDARD HOSE (Not Shown)	2	
18	45650	HOT AIR LANCE (NOT SHOWN)	1	

†This item is recommended for standard hose connection in the heat compartment. One required per hose.

Chapter 8 Illustrated Parts List

This page left blank intentionally

Chapter 8 Illustrated Parts List

9.4 Tank Assembly

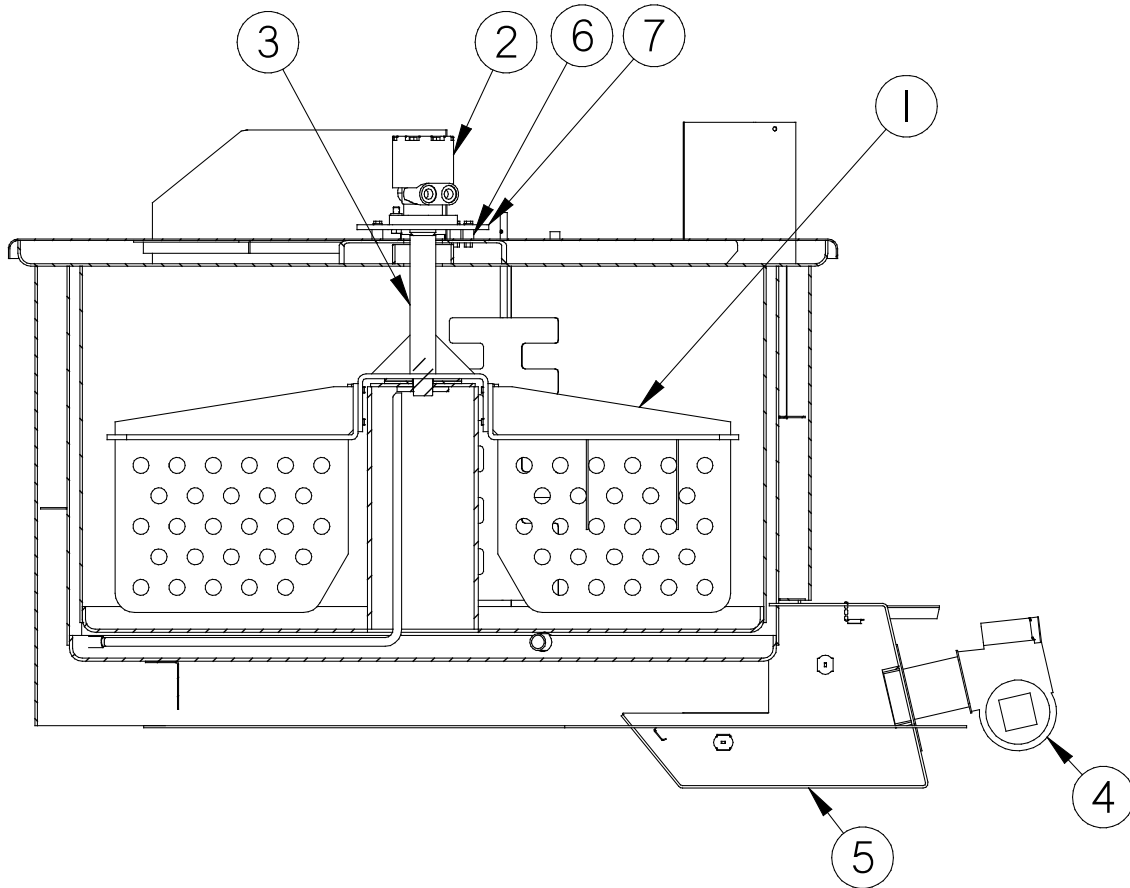

Fig. 9.5 Tank Detail

FIG.	ITEM	PART NO.	DESCRIPTION	QTY.
Fig. 9.5	1	46531	PADDLE, AGITATOR	2
	2	45706	MOTOR, HYDRAULIC – AGITATOR	1
	3	46050	SHAFT ASSEMBLY – AGITATOR	1
	4	46380	BURNER, 14 VOLT DIESEL	1
	5	46560	BURNER BOX ASSEMBLY, EXTENDED	1
	5a	45734	BURNER BOX INSULATION KIT	1
	6	42573	MOUNTING PLATE – MOTOR	1
	7	40030	SPACER. MOTOR	4

Chapter 8 Illustrated Parts List

9.5 Plumbing Assembly

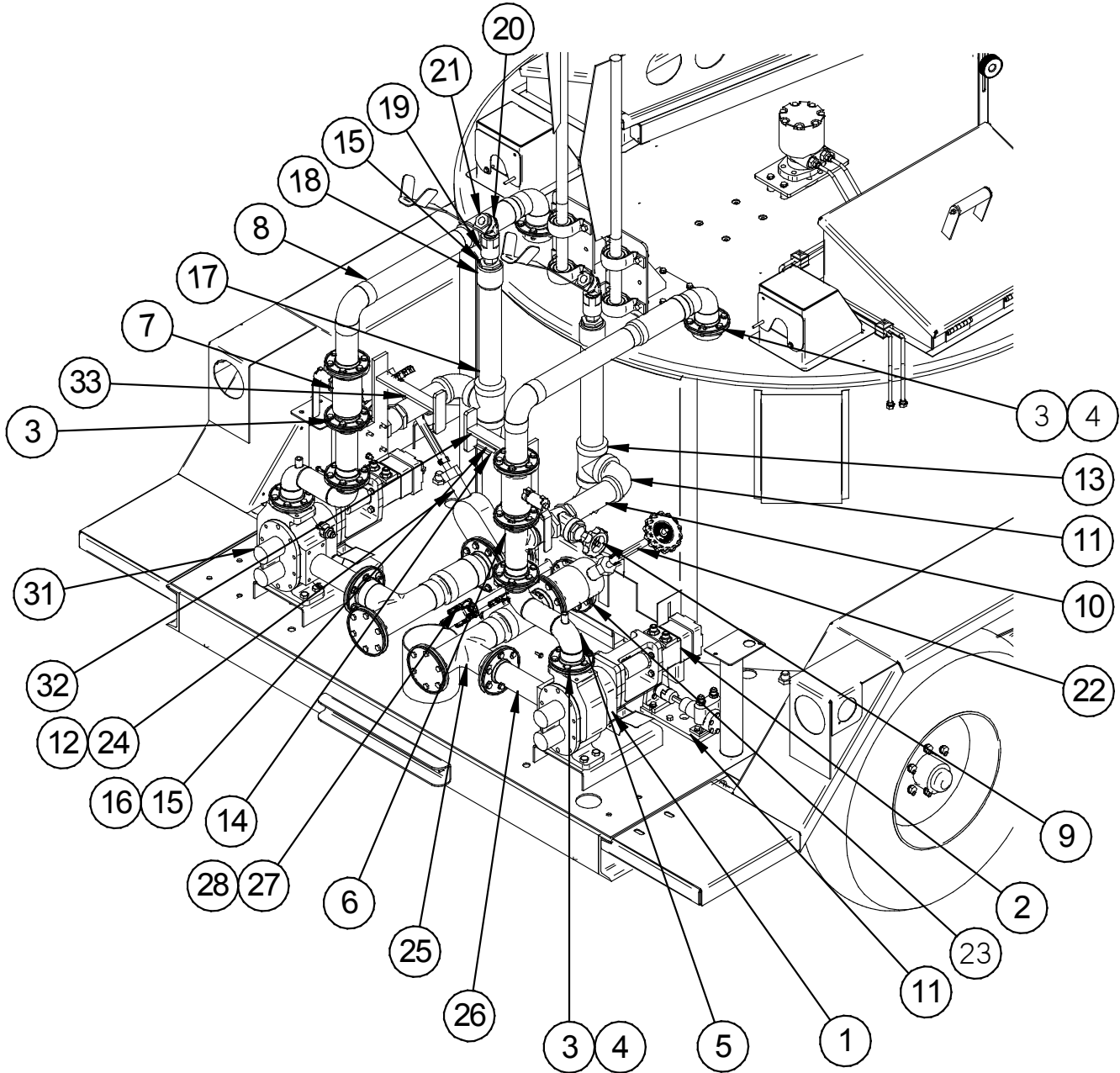

Fig. 9.6 Plumbing

Chapter 8 Illustrated Parts List

FIG.	ITEM	PART NO.	DESCRIPTION	QTY.
Fig. 9.6	1	43127	PUMP ASSEMBLY, P.S.	1
	2	22027	HYDRAULIC MOTOR	2
	3	22030	NIPPLE ASSEMBLY, FLANGED	6
	4	29050	GASKET, 2" CIRCULAR FLANGED	9
	5	46547	ELBOW, DOUBLE	2
	6	46644	FLANGED TEE	2
	7	41246	VALVE, 2" BALL	2
	8	46642	PIPING ASSEMBLY, UPPER	2
	9	29270	VALVE, 2" GATE	2
	10	28110	NIPPLE, 2" NPT X 8" LG.	2
	11	28243	ELBOW, 2" STREET	2
	12	29060	GASKET, 3" CIRCULAR FLANGED	4
	13	25258	TEE, 2" PIPE	2
	14	28242	ELBOW, 2" 45° STREET	2
	15	28358	BUSHING, 2" X 1" HEX HEAD REDUCER	4
	16	28285	PLUG, 1" SQ. HEAD PIPE	2
	17	28190	NIPPLE, 2" NPT X 14 1/2" LG.	2
	18	28183	COUPLING, 2" PIPE	2
	19	27048	SWIVEL, 1" PIPE	2
	20	28225	ELBOW, 1" STREET	2
	21	28351	BUSHING, 1" X 3/4" HEX HEAD REDUCER	2
	22	46509	EXTENSION, VALVE HANDLE	2
	23	46570	DRAIN PIPE EXTENSION	2
	24	29292	VALVE, 3" FLANGED GATE	2
	25	46645	PIPE ASSEMBLY, MATERIAL SUCTION	2
	26	46549	MATERIAL PIPE ASSEMBLY, PUMP SUCTION	2
	27	41499	VALVE, HOT OIL	2
	28	29845	ADAPTER	2
	29	41404	FLEX HOSE ASSEMBLY, HOT OIL (Not Shown)	3
	30	41403	FLEX HOSE ASSEMBLY, HOT OIL (Not Shown)	1
	31	43126	PUMP ASSEMBLY, D.S.	1
	32	46638	HOSE HANGER ASSEMBLY	1
	33	46635	HOSE HANGER, D.S.	1

Chapter 8 Illustrated Parts List

9.6 Control Box Assembly – Electric Hose

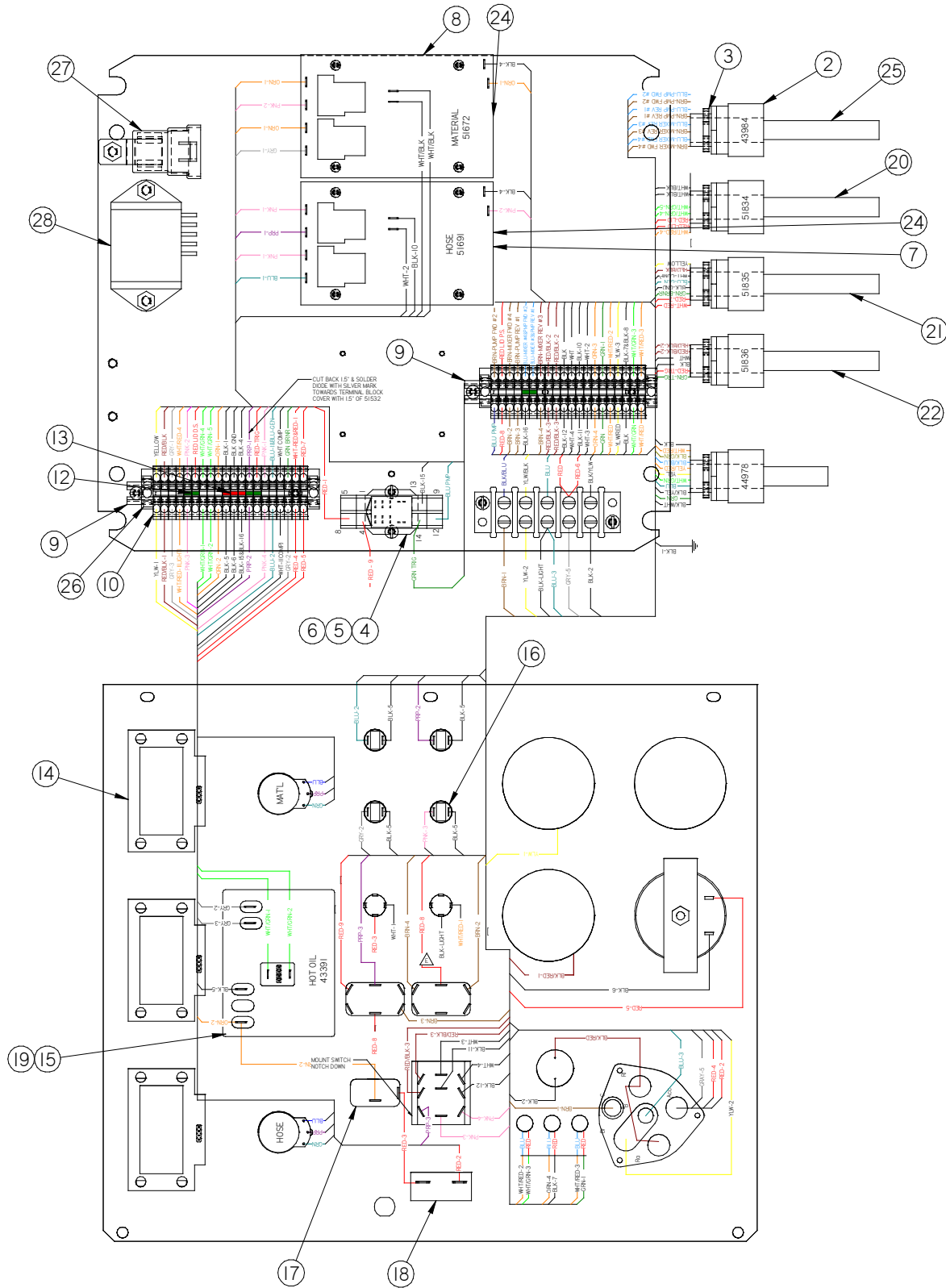

Fig. 9.7 Control Box Assembly 46500EB

Chapter 8 Illustrated Parts List

FIG.	ITEM	PART NO.	DESCRIPTION	QTY.
Fig. 9.7	1	45595	ENCLOSURE (NOT SHOWN)	1
	2	24024	CORD CONNECTOR	3
	3	50280	1/2" CONDUIT NUT	5
	4	51662	SOCKET, RELAY	1
	5	51661	RELAY	1
	6	51663	HOLD DOWN SPRING	1
	7	51691	TEMPERATURE CONTROLLER, 400°/325°	1
	8	51672	TEMPERATURE CONTROLLER, 400°/275°	1
	9	51803	MOUNTING RAIL	2
	10	51802	END BRACKET	2
	11	51800	FEED THROUGH TERMINAL	40
	12	51801	JUMPER, 2-POLE	3
	13	51804	JUMPER, 3-POLE	1
	14	50251	READOUT, DIGITAL	3
	15	43391	TEMPERATURE CONTROLLER 150°-550°	1
	16	51651	LIGHT, 12VDC	4
	17	50719	SWITCH, TOGGLE	2
	18	51665	CIRCUIT BREAKER, 15 AMP	1
	19	50593	KNOB	3
	20	51834	CABLE ASSEMBLY, SENSOR	1
	21	51835	CABLE ASSEMBLY, POWER	1
	22	51836	CABLE ASSEMBLY, TRIGGER/SENSOR	1
	23	51684	RIBBON CABLE, 36" (NOT SHOWN)	2
	24	51670	SPACER, TEMPERATURE CONTROLLER	8
	25	43984	CABLE ASSEMBLY, VALVE	1
	26	51805	END BRACKET	4
	27	44979	RELAY, STARTER	2
	28	44980	TIMER	1
	29	-	RELAY	1

Chapter 8 Illustrated Parts List

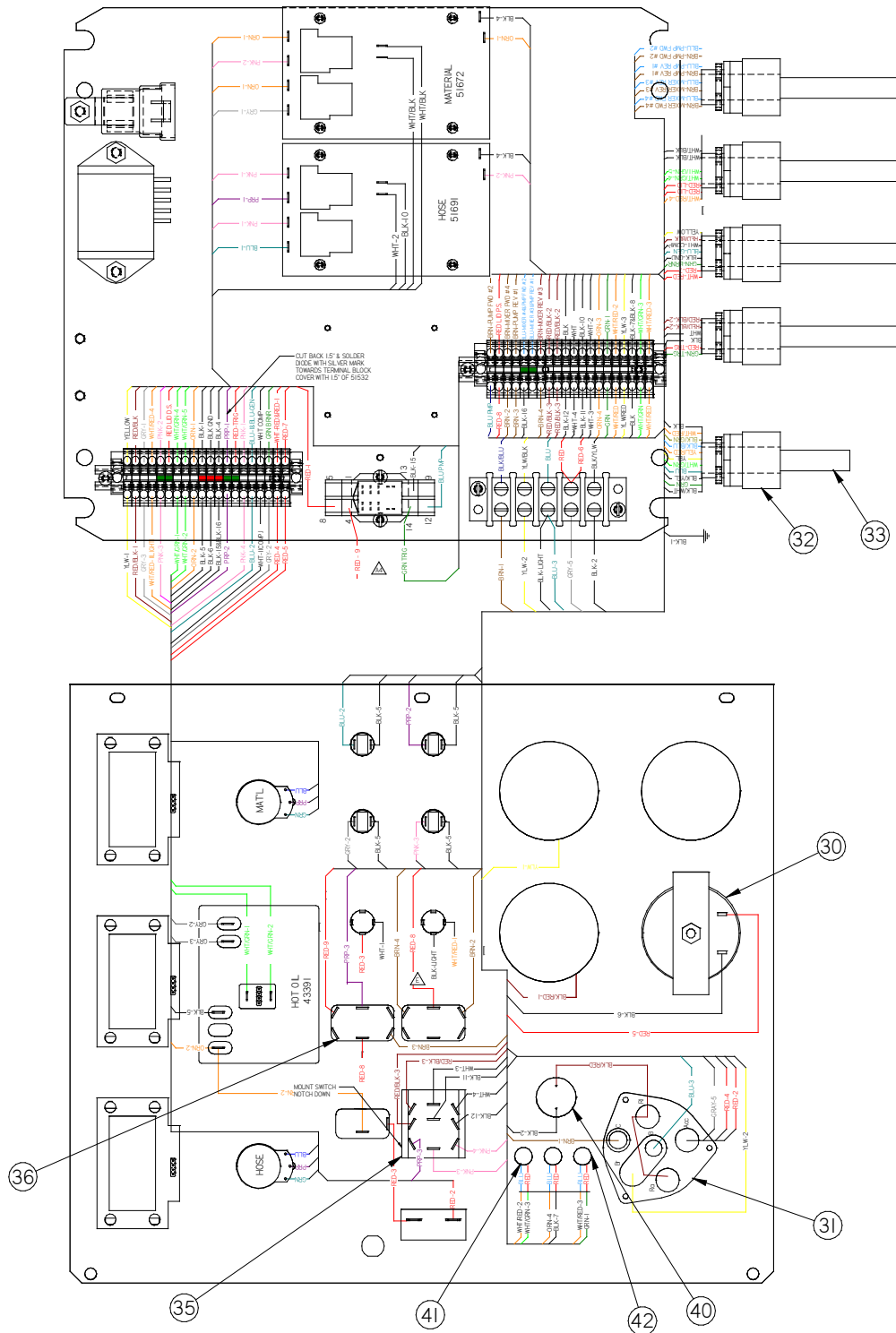

Fig. 9.8 Control Box Assembly: 46500EB

Chapter 8 Illustrated Parts List

FIG.	ITEM	PART NO.	DESCRIPTION	QTY.
Fig. 9.8	30	24076	HOUR METER	1
	31	41994	IGNITION SWITCH	1
	32	24024	CORD GRIP, YELLO2W	1
	33.	44978	CABLE ASSEMBLY, ENGINE	1
	34	51698	RIBBON CABLE, 5"	1
	35	51811	SWITCH, HOSE SELECTOR	1
	36	32522	SWITCH, PUMP	1
	37	44975	GAUGE, WATER TEMPERATURE (Not Shown)	OPT.
	38	44976	GAUGE, OIL PRESSURE (Not Shown)	OPT.
	39	44977	GAUGE, VOLT METER (Not Shown)	OPT.
	40	44987	RESISTANCE CONTROL	1
	41	44989	LIGHT, AMBER	2
	42	44988	LIGHT, RED	1

Chapter 8 Illustrated Parts List

9.7 Control Box Assembly, D.S. –Electric Hose

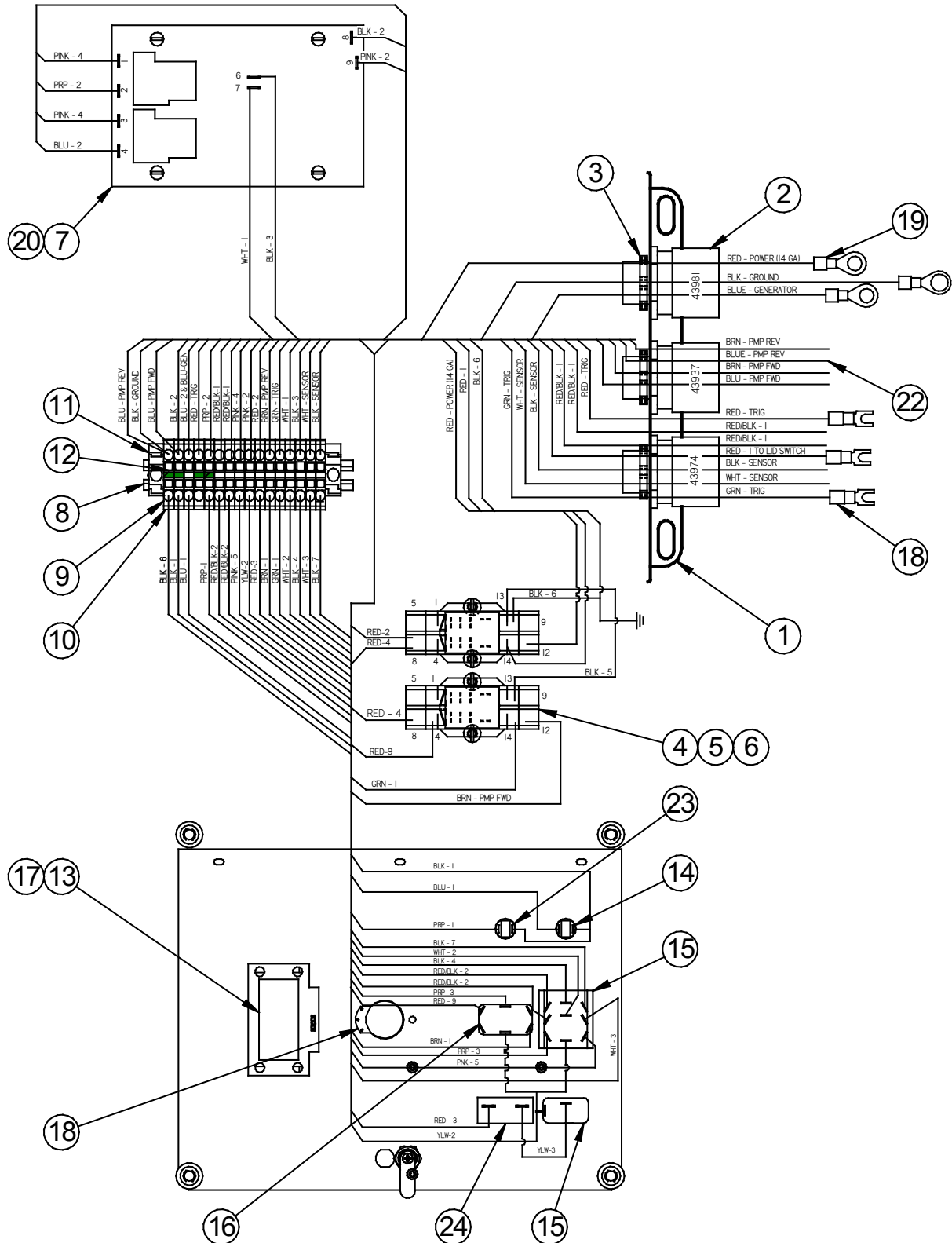

Fig. 9.9 Control Box Assembly – D.S. Electric

Chapter 8 Illustrated Parts List

FIG.	ITEM	PART NO.	DESCRIPTION	QTY.
Fig. 9.9	1	44860	ENCLOSURE (NOT SHOWN)	1
	2	24021	CORD CONNECTOR	3
	3	50280	1/2" CONDUIT NUT	3
	4	51662	SOCKET, RELAY	2
	5	51661	RELAY	2
	6	51663	HOLD DOWN SPRING	2
	7	51672	TEMPERATURE CONTROLLER, 400°/275°	1
	8	51803	MOUNTING RAIL	2
	9	51802	END BRACKET	2
	10	51800	FEED THROUGH TERMINAL	16
	11	51805	END BRACKET	2
	12	51801	JUMPER, 2-POLE	2
	13	50251	READOUT, DIGITAL	1
	14	51651	LIGHT, 12VDC	2
	15	51811	SWITCH, HOSE SELECTOR	2
	16	32522	SWITCH, PUMP	1
	17	50593	KNOB	1
	18	43974	CABLE ASSEMBLY, SENSOR	1
	19	43981	CABLE ASSEMBLY, TRIGGER	1
	20	51684	RIBBON CABLE, 36" (NOT SHOWN)	1
	21	51670	SPACER, TEMPERATURE CONTROLLER	4
	22	43937	CABLE ASSEMBLY, VALVE	1
	23	51665	CIRCUIT BREAKER	1

Chapter 8 Illustrated Parts List

9.8 Control Box Assembly – Standard Hose

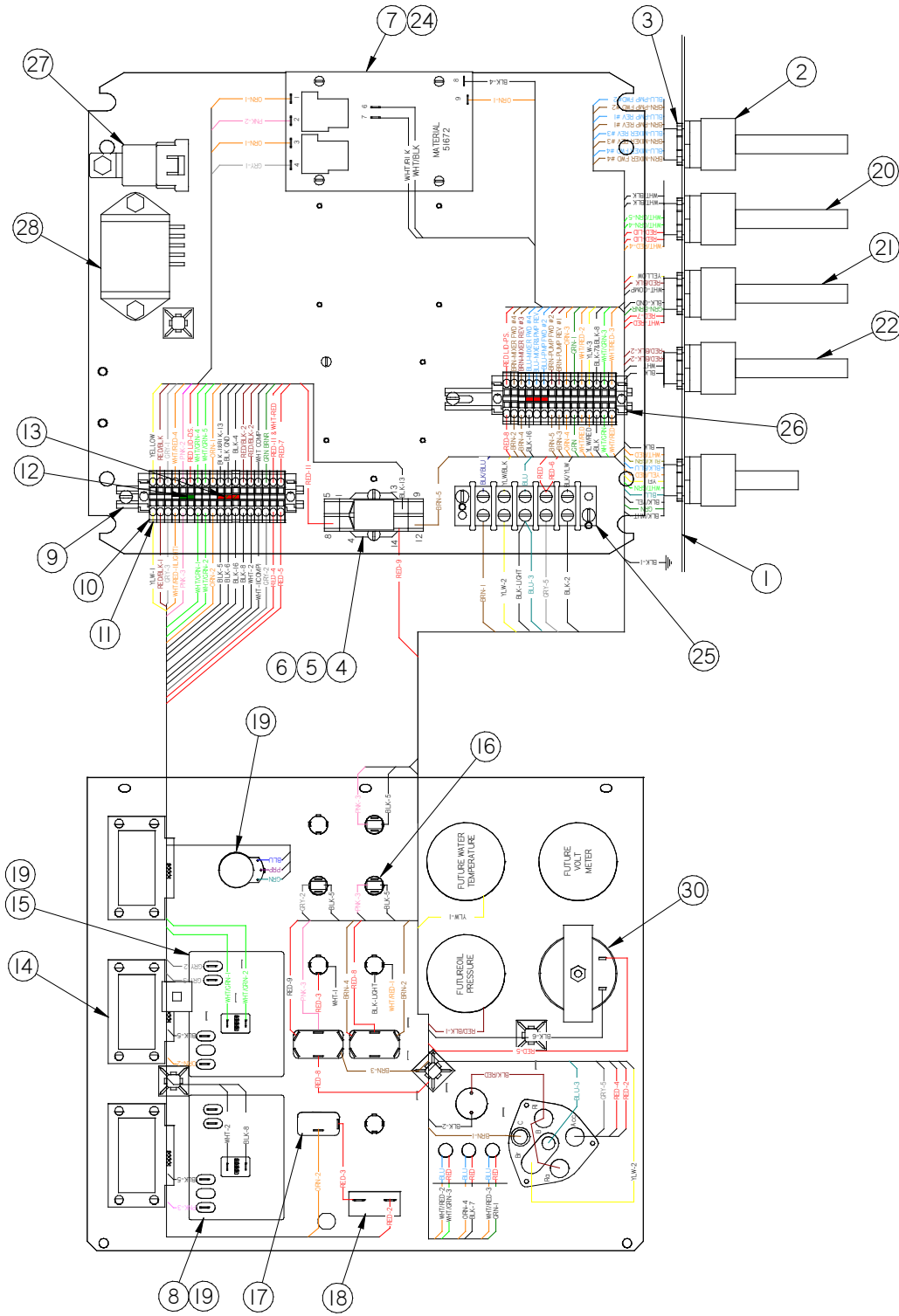

Fig. 9.10 Control Box Assembly: 4650SB

Chapter 8 Illustrated Parts List

FIG.	ITEM	PART NO.	DESCRIPTION	QTY.
Fig. 9.10	1	45595	ENCLOSURE (NOT SHOWN)	1
	2	24021	CORD CONNECTOR	3
	3	50280	1/2" CONDUIT NUT	5
	4	51662	SOCKET, RELAY	1
	5	51661	RELAY	1
	6	51663	HOLD DOWN SPRING	1
	7	51672	TEMPERATURE CONTROLLER, 400°/275°	1
	8	43397	TEMPERATURE CONTROLLER, 400°	1
	9	51803	MOUNTING RAIL	2
	10	51802	END PLATE	2
	11	51800	FEED THROUGH TERMINAL	33
	12	51801	JUMPER, 2-POLE	1
	13	51804	JUMPER, 3-POLE	2
	14	50251	READOUT, DIGITAL	3
	15	43391	TEMPERATURE CONTROLLER 150°-550°	1
	16	51651	LIGHT, 12VDC	3
	17	50719	SWITCH, TOGGLE	2
	18	51665	CIRCUIT BREAKER, 15 AMP	1
	19	50593	KNOB	3
	20	51834	CABLE ASSEMBLY, SENSOR	1
	21	51835	CABLE ASSEMBLY, POWER	1
	22	51836	CABLE ASSEMBLY, TRIGGER/SENSOR	1
	23	51684	RIBBON CABLE, 36" (NOT SHOWN)	1
	24	51670	SPACER, TEMPERATURE CONTRLLER	4
	25	44994	TERMINAL BLOCK 5-POLE	1
	26	51805	END BRACKET	4
	27	44979	RELAY, STARTER	2
	28	44980	TIMER	1
	29	51673	RELAY (NOT SHOWN)	1
	30	24076	HOUR METER	1

Chapter 8 Illustrated Parts List

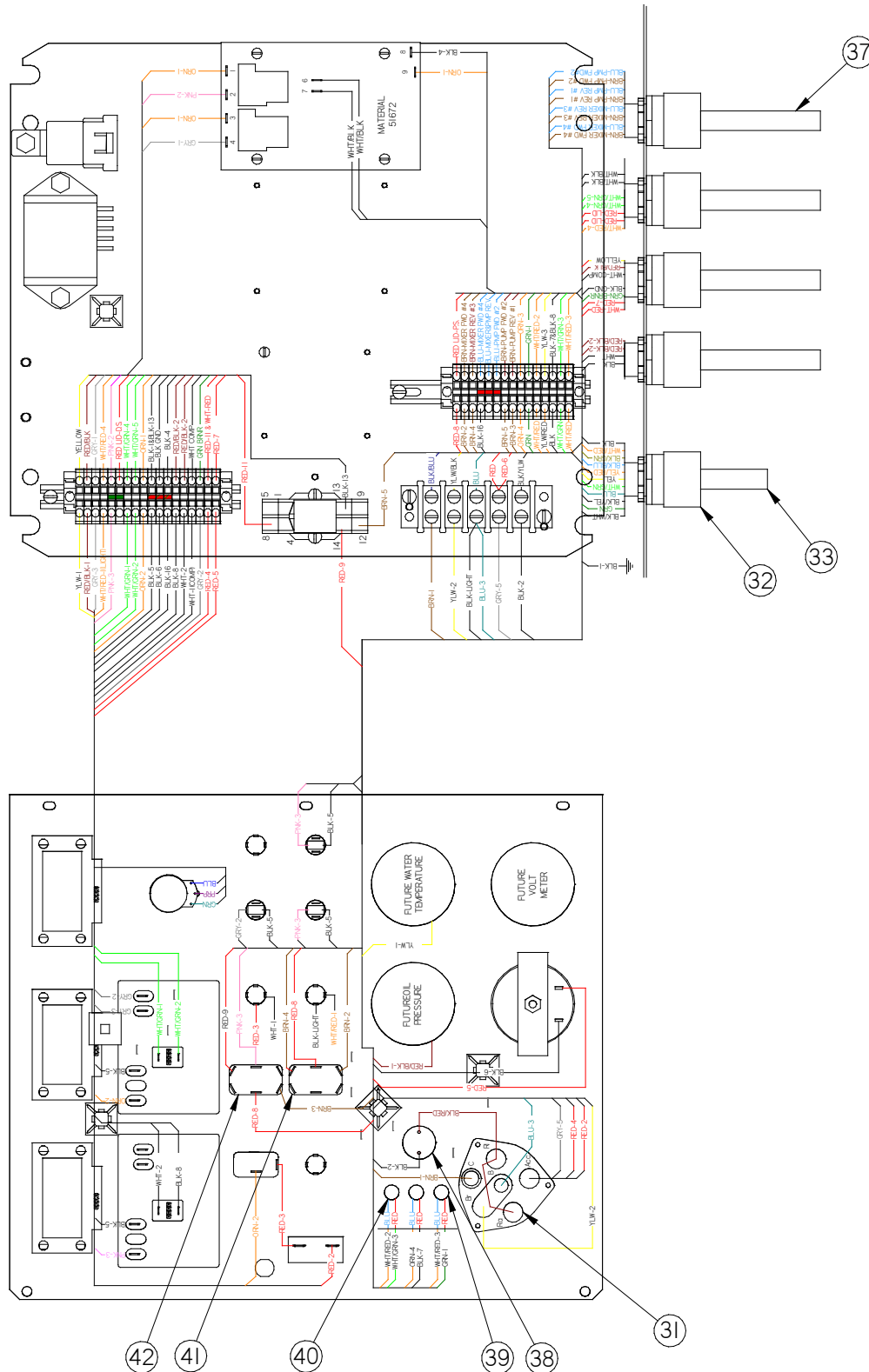

Fig. 9.11 Control Box Assembly: 4650SB

Chapter 8 Illustrated Parts List

FIG.	ITEM	PART NO.	DESCRIPTION	QTY.
Fig. 9.11	31	44990	KEY AND TUMBLER	1
	31a	41994	IGNITION SWITCH W/O TUMBLER	1
	32	24024	CORD GRIP, YELLOW	2
	33	44978	CABLE ASSEMBLY, ENGINE	1
	34	51698	RIBBON CABLE, 5" (NOT SHOWN)	2
	35	44976	GAUGE, OIL PRESSURE (NOT SHOWN)	OPT.
	36	44977	GAUGE, VOLT METER (NOT SHOWN)	OPT.
	37	43984	CABLE ASSEMBLY, VALVE	1
	38	44987	RESISTANCE CONTROL	1
	39	44989	LIGHT, AMBER	1
	40	44988	LIGHT, RED	2
	41	51678	SWITCH, DPDT	2
	42	32522	SWITCH, PUMP	1

Chapter 8 Illustrated Parts List

9.9 Control Box Assembly, D.S. – Standard Hose

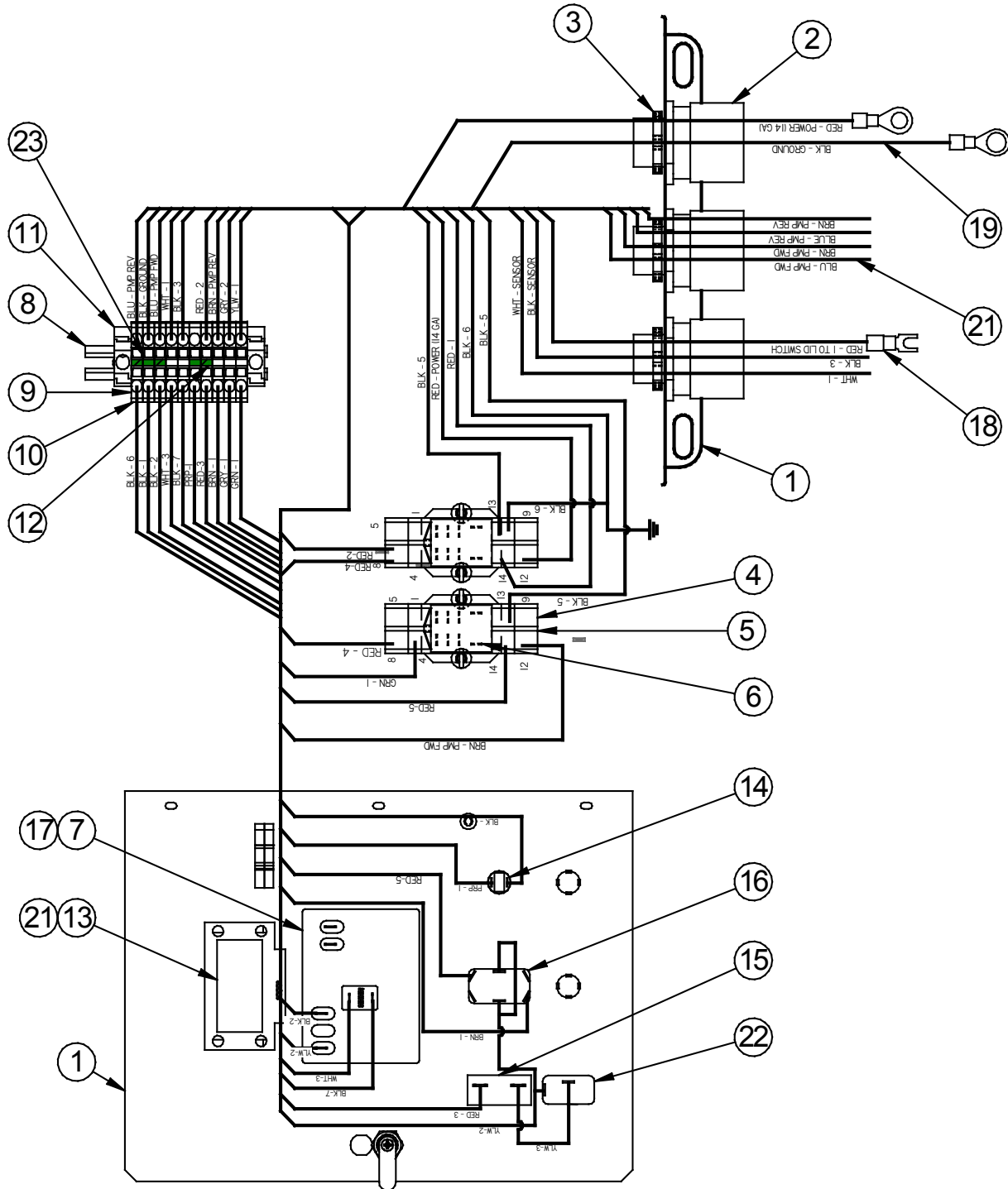

Fig. 9.12 Control Box Assembly, D.S. – Standard Hose

Chapter 8 Illustrated Parts List

FIG.	ITEM	PART NO.	DESCRIPTION	QTY.
Fig. 9.12	1	44860	ENCLOSURE (NOT SHOWN)	1
	2	24021	CORD CONNECTOR	3
	3	50280	1/2" CONDUIT NUT	3
	4	51662	SOCKET, RELAY	2
	5	51661	RELAY	2
	6	51663	HOLD DOWN SPRING	2
	7	43397	TEMPERATURE CONTROLLER, 400°	1
	8	51803	MOUNTING RAIL	2
	9	51802	END BRACKET	1
	10	51800	FEED THROUGH TERMINAL	8
	11	51805	END BRACKET	2
	12	51801	JUMPER, 2-POLE	1
	13	50251	READOUT, DIGITAL	1
	14	51651	LIGHT, 12VDC	2
	15	51665	CIRCUIT BREAKER	1
	16	32522	SWITCH, PUMP	1
	17	50593	KNOB	1
	18	51819	CABLE ASSEMBLY, SENSOR	1
	19	43981	CABLE ASSEMBLY, TRIGGER	1
	20	51698	RIBBON CABLE, 5" (NOT SHOWN)	1
	21	43937	CABLE ASSEMBLY, VALVE	1
	22	50719	SWITCH, POWER	1

Chapter 8 Illustrated Parts List

9.10 Engine Assembly – 46500SB

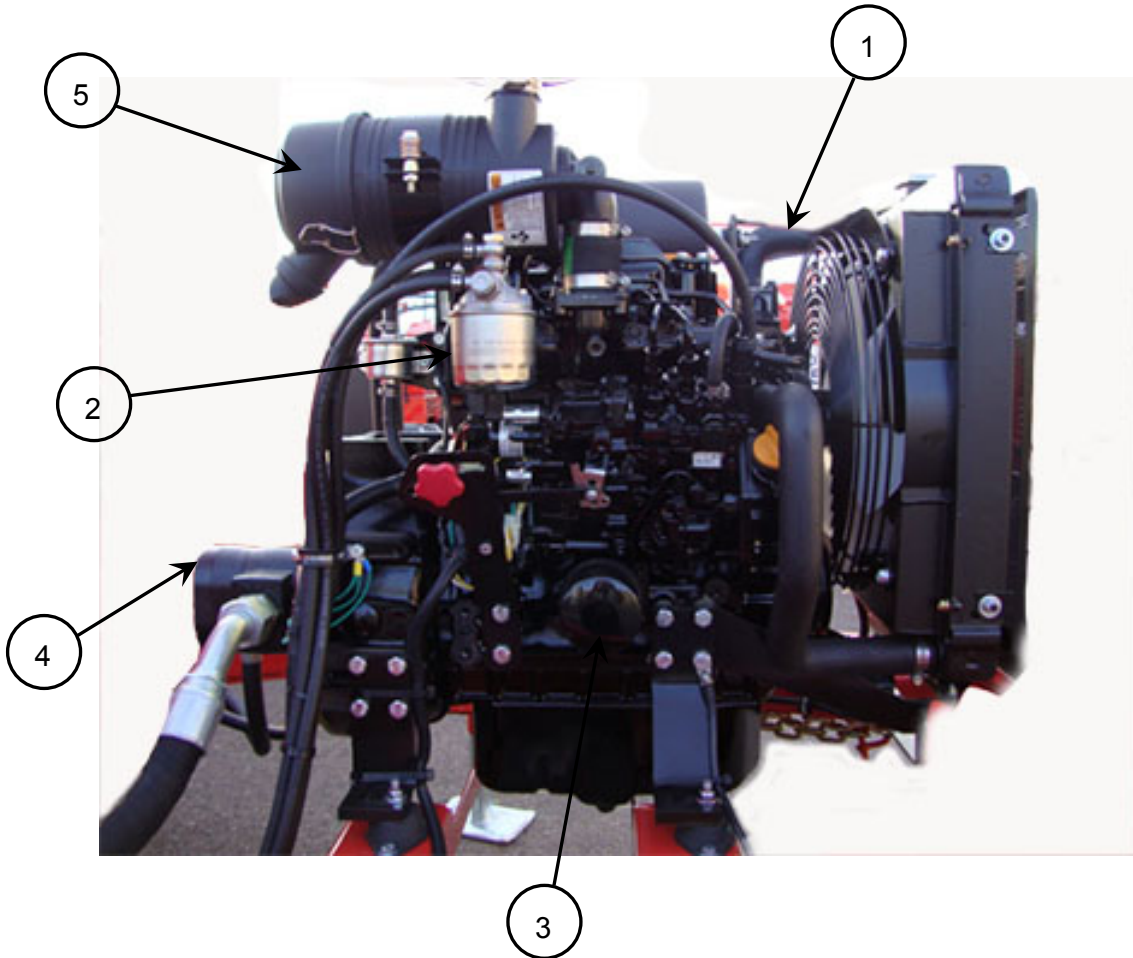

Fig. 9.13 Engine Assembly - 46500SB

FIG.	ITEM	PART NO.	DESCRIPTION	QTY.
Fig. 9.13	1	46727	35.5 HP ENGINE	1
	2	41867	FUEL FILTER	1
	3	45381	OIL FILTER	1
	4	45446	HYDRAULIC PUMP	1
	5	45383	AIR FILTER ELEMENT	1
	8	45386	SERVICE MANUAL	OPT.
	9	45384	PARTS MANUAL	OPT.
	10	43857	OWNERS MANUAL	1

Chapter 8 Illustrated Parts List

9.11 Engine Assembly – 46500EB

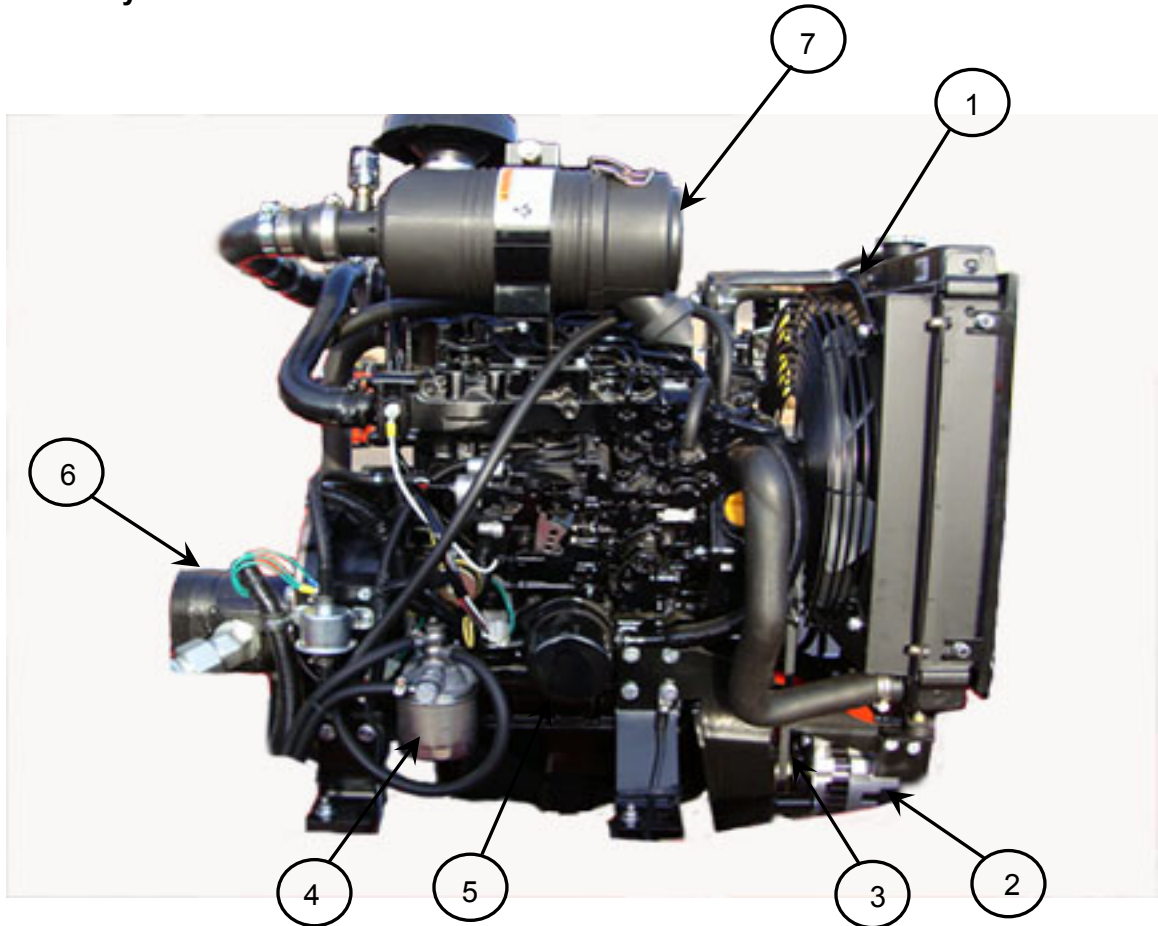

Fig. 9.14 Engine Assembly - 46500EB

FIG.	ITEM	PART NO.	DESCRIPTION	QTY.
Fig. 9.14	1	46718	41.6 HP ENGINE W/ DUAL GENERATOR	1
	2	46322	GENERATOR, 24VAC	2
	3	46323	BELT, DRIVE – GENERATOR	1
	3a	46324	TENSIONER, BELT (NOT SHOWN)	1
	4	41867	FUEL FILTER	1
	5	45381	OIL FILTER	1
	6	45446	HYDRAULIC PUMP	1
	7	45348	AIR FILTER ELEMENT	1
	8	45383	SERVICE MANUAL	OPT.
	9	45384	PARTS MANUAL	OPT.
	10	43857	OWNERS MANUAL	1

Chapter 8 Illustrated Parts List

9.12 Hydraulic Control Valve Assembly – Passenger Side

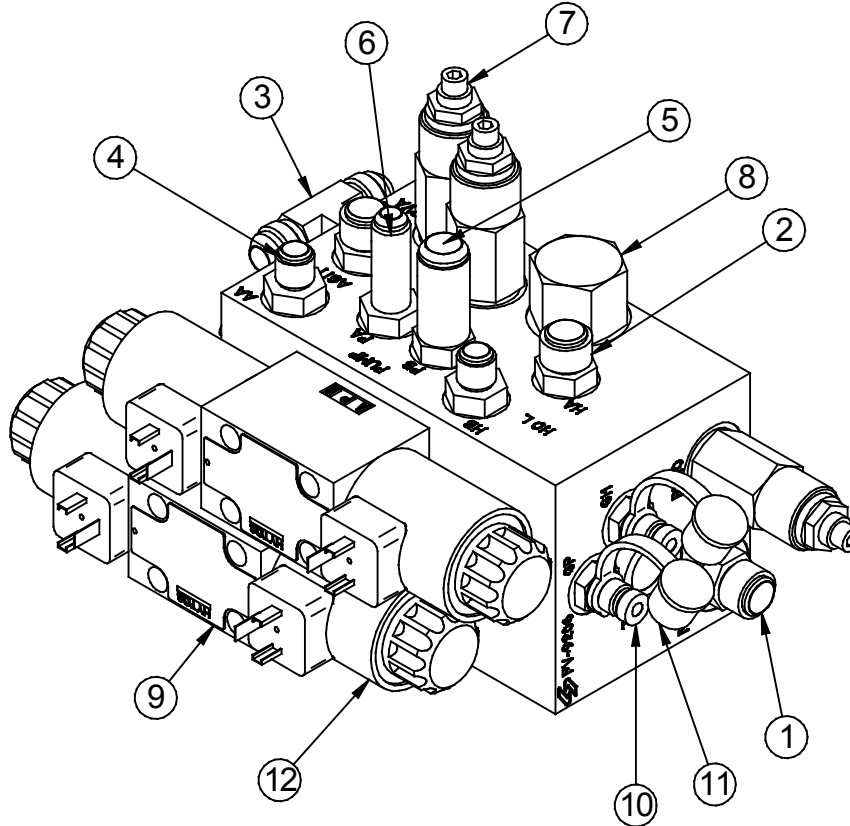

Fig. 9.15 Hydraulic Control Valve P.S

FIG.	ITEM	PART NO.	DESCRIPTION	QTY.
Fig. 9.15	1	29896	3/4-16 ORB X #8 JIC STR.	1
	2	29919	9/16-18 ORB X #8 JIC STR.	3
	3	29976	3/4-16 ORB X #8 JIC BRANCH TEE	1
	4	40311	9/16-18 ORB X #6 JIC STR.	2
	5	40320	9/16-18 ORING X #8 JIC STR.	2
	6	40308	9/16-18 ORB X #6 JIC LONG STR.	1
	7	45417	RELIEF VALVE	3
	8	45416	FLOW DIVIDER	2
	9	45418	VALVE, DIRECTIONAL	2
	10	45414	FITTING, TEST POINT	3
	11	45413	CAP, DUST – TEST POINT	3
	12	45436	COIL, HYDRAULIC VALVE	4

Chapter 8 Illustrated Parts List

9.13 Hydraulic Control Valve – Drivers Side

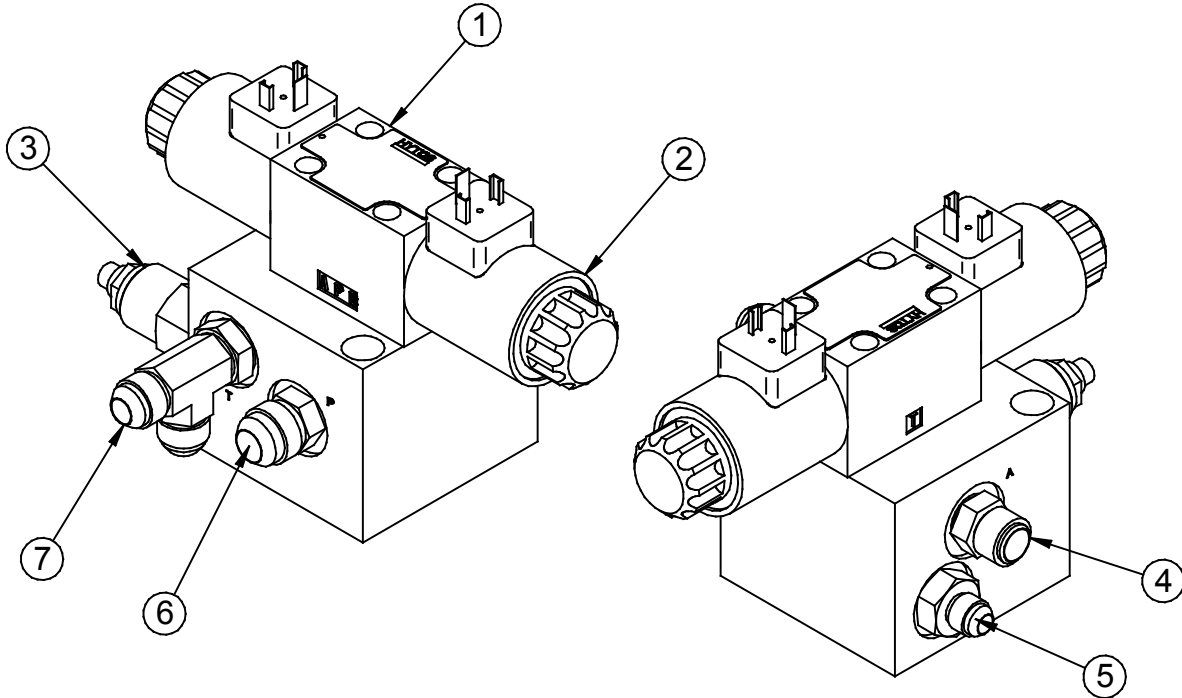

Fig. 9.16 Hydraulic Control Valve, D.S.

FIG.	ITEM	PART NO.	DESCRIPTION	QTY.
Fig. 9.16	1	45418	VALVE, DIRECTIONAL	1
	2	45436	COIL, HYDRAULIC VALVE	2
	3	45417	RELIEF VALVE	1
	4	29897	3/4-16 ORB X #8 JIC STR.	1
	5	29998	3/4-16 ORB X #6 JIC STR.	1
	6	29908	3/4-16 ORB X #10 JIC STR.	1
	7	29932	3/4-16 ORB X #8 JIC RUN TEE.	1

Chapter 8 Illustrated Parts List

9.14 Burner Assembly

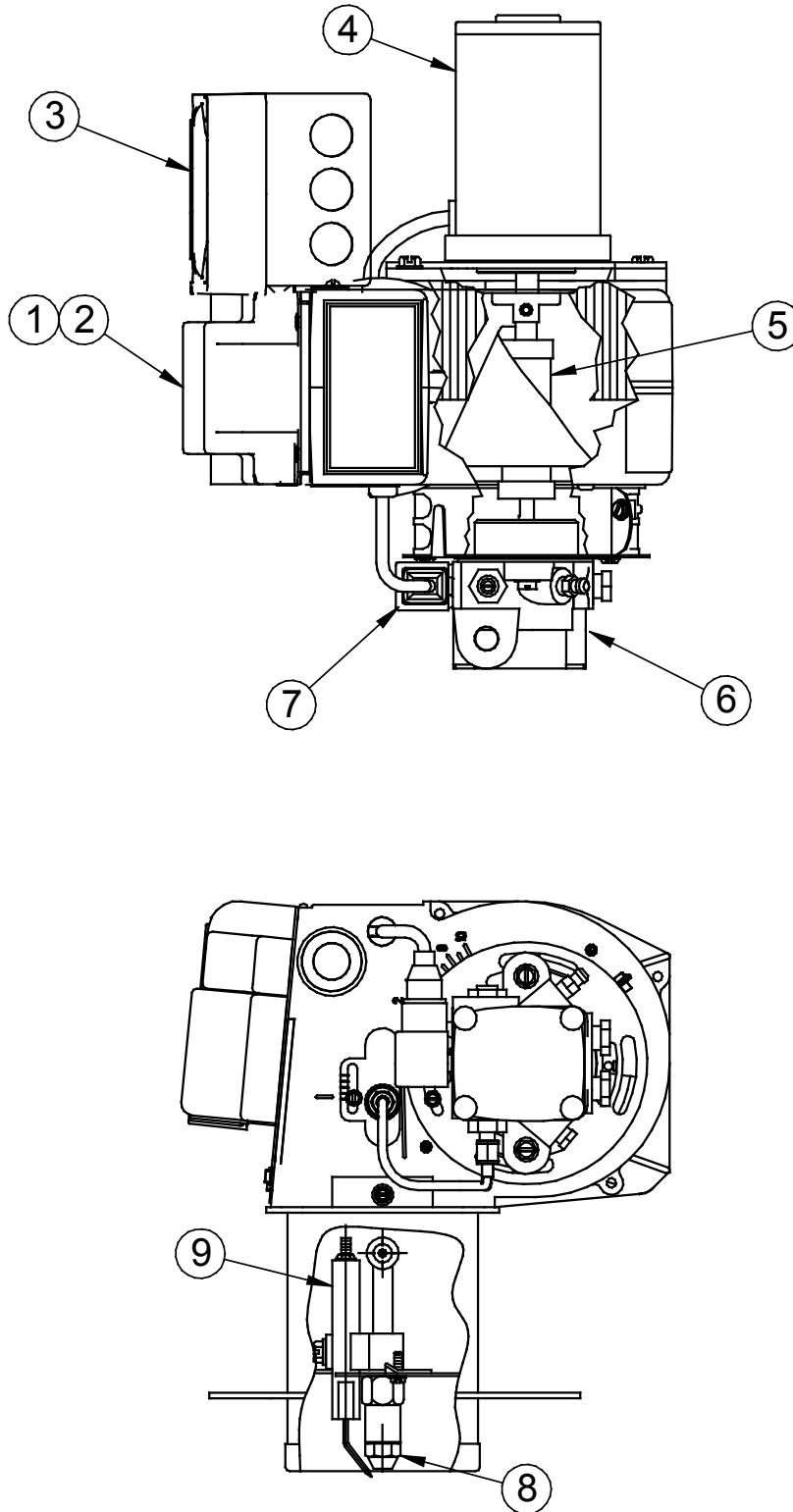

Fig. 9.17 Diesel Burner

Chapter 8 Illustrated Parts List

FIG.	ITEM	PART NO.	DESCRIPTION	QTY.
Fig. 9.17	1	41949	IGNITION TRANSFORMER	1
	2	41870	CAD EYE (NOT SHOWN)	1
	3	42335	DC CONTROLLER (NOT SHOWN)	1
	4	41890	BLOWER MOTOR	1
	5	41970	COUPLING, FUEL PUMP	1
	6	41892	PUMP, FUEL	1
	7	41888	SOLENOID, FUEL	1
	8	41883	NOZZLE	1
	9	41993	ELECTRODE	1
	10	24258	DIESEL GAUGE KIT (SEE Figure 8.3)	OPT.

Chapter 8 Illustrated Parts List

9.15 Material Pump Assembly – Passenger Side

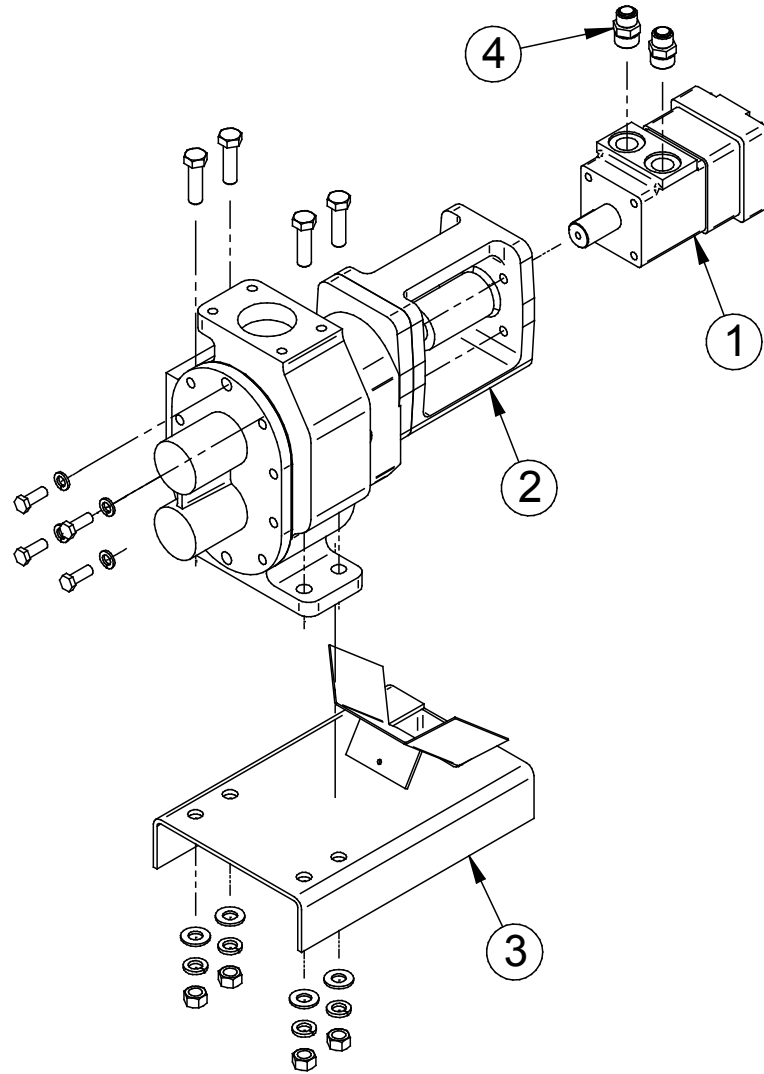

Fig. 9.18 Material Pump Assembly, P.S.

FIG.	ITEM	PART NO.	DESCRIPTION	QTY.
Fig. 9.18	1	22027	MOTOR, HYDRAULIC	1
	2	42070	PUMP ASSEMBLY, JACKETED – P.S.	1
	2a	29990S	PACKING RING (SET OF 7)	1
	3	43129	MOUNTING PLATE ASSEMBLY	1
	4	22029	FITTING, #10 ORB X #6 JIC STRAIGHT	2

Chapter 8 Illustrated Parts List

9.16 Material Pump Assembly – Drivers Side

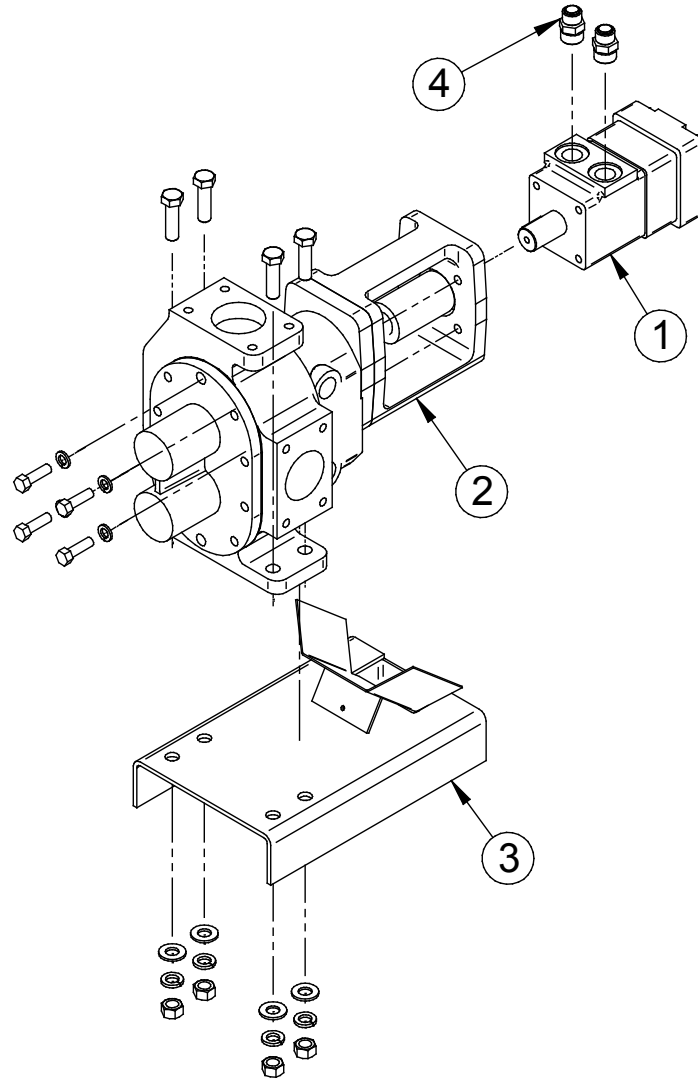

Fig. 9.19 Material Pump Assembly, D.S.

FIG.	ITEM	PART NO.	DESCRIPTION	QTY.
Fig. 9.19	1	22027	MOTOR, HYDRAULIC	1
	2	42072	PUMP ASSEMBLY, JACKETED – D.S.	1
	2a	29990S	PACKING RING (SET OF 7)	1
	3	43129	MOUNTING PLATE ASSEMBLY	1
	4	22029	FITTING, #10 ORB X #6 JIC STRAIGHT	2

Chapter 8 Illustrated Parts List

9.17 Hydraulic Diagram

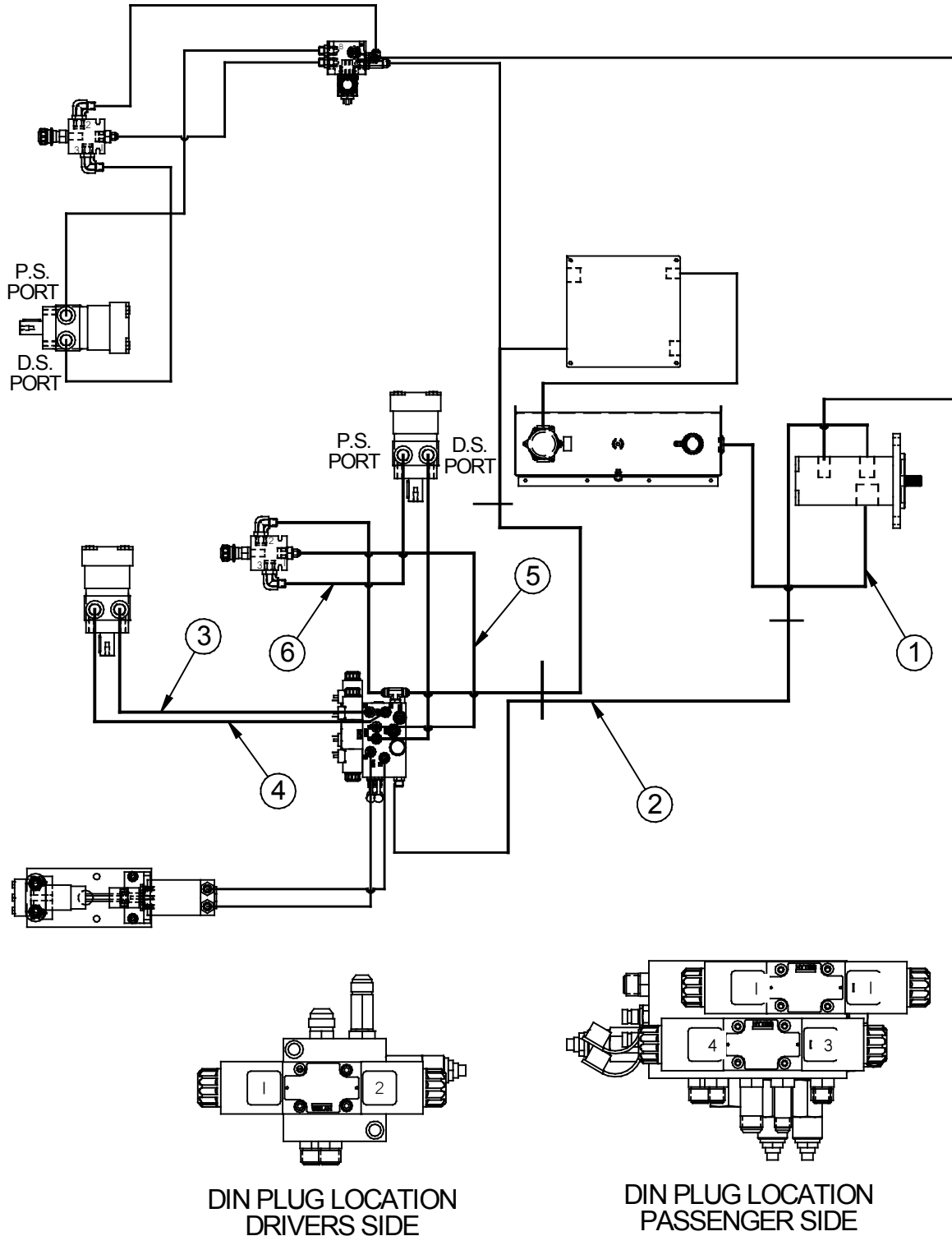
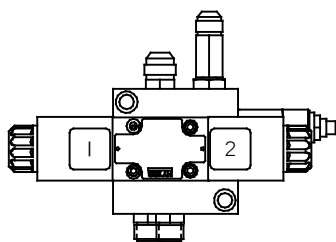
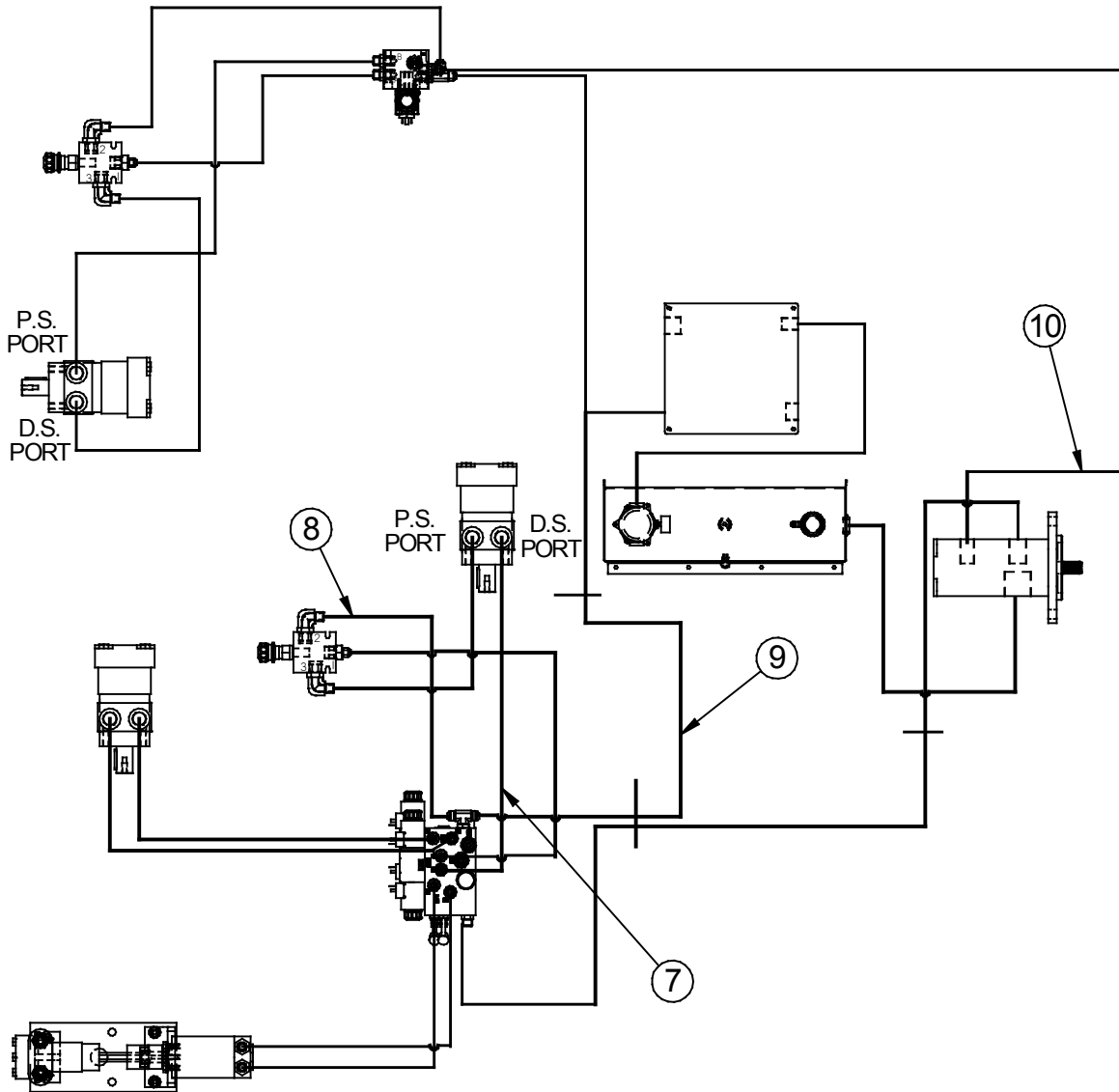

Fig. 9.20 Hydraulic Diagram

Chapter 8 Illustrated Parts List

FIG.	ITEM	PART NO.	DESCRIPTION	QTY
Fig. 9.20	1	HYDRAULIC RESERVOIR TO HYDRAULIC PUMP SUCTION PORT		
		2988	FITTING, #20 ORB X #20 JIC 45°	1
		20G4H 20G-20FJX45 20G-20FJX 25	HYDRAULIC HOSE	1
		29885	FITTING, #20 ORB X #20 JIC STR.	1
	2	HYDRAULIC PUMP TO HYDRAULIC VALVE "P" PORT		
		29821	FITTING, #12 ORB X #10 JIC STR.	1
		8M3K 8G-10FJX90S 8G-10FJX 24	HYDRAULIC HOSE	1
		29805	FITTING, #10 JIC BULKHEAD	1
		29807	NUT, BULKHEAD FITTING	1
		46433	TUBE, HYDRAULIC PRESSURE	1
		8M3K 8G-8FJX90S 8G-10FJX 31	HYDRAULIC HOSE	1
		29897	FITTING, #12 ORB X #8 JIC STR.	1
	3	HYDRAULIC VALVE "AA" PORT TO AGITATOR MOTOR REAR PORT		
		40311	FITTING, #6 ORB X #6 JIC STR.	1
		6M3K 6G-6FJX90S 6G-FJX 34	HYDRAULIC HOSE	1
		29808	FITTING, #6 JIC X #6 JIC UNION	1
		46504	TUBE, HYDRAULIC PRESSURE	1
		22029	FITTING, #10 ORB X #6 JIC STR.	1
	4	AGITATOR MOTOR (FRONT PORT) TO HYDRAULIC VALVE "AB" PORT		
		22029	FITTING, #10 ORB X #6 JIC STR.	1
		46503	TUBE, HYDRAULIC RETURN	1
		29808	FITTING, #6 JIC X #6 JIC UNION	1
		6M3K 6G-6FJX 6G-8FJX90S 35	HYDRAULIC HOSE	1
	29919	FITTING, #6 ORB X #8 JIC	1	
5	HYDRAULIC VALVE "PA" TO FLOW CONTROL #1 PORT			
	40308	FITTING, #6 ORB X #6 JIC LONG	1	
	6M3K 6G-6FJX90L 6G-8FJX 16	HYDRAULIC HOSE	1	
	29896	FITTING, #8 ORB X #8 JIC 90°	1	
6	FLOW CONTROL #3 PORT TO PUMP MOTOR (PASS. SIDE PORT)			
	29896	FITTING, #8 ORB X #8 JIC 90°	1	
	8M3K 8G-8FJX90L 8G-8FJX 31	HYDRAULIC HOSE	1	
	29913	FITTING, #10 ORB X #8 JIC STR.	1	

Chapter 8 Illustrated Parts List



**DIN PLUG LOCATION
DRIVERS SIDE**

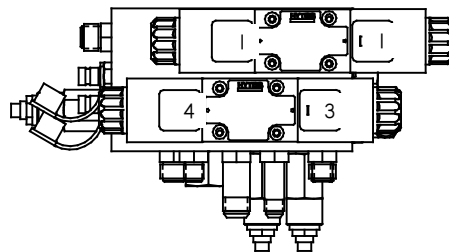

**DIN PLUG LOCATION
PASSENGER SIDE**

Fig. 9.21 Hydraulic Diagram

Chapter 8 Illustrated Parts List

FIG.	ITEM	PART NO.	DESCRIPTION	QTY.
Fig. 9.21	7	PUMP MOTOR (OVEN SIDE PORT) TO HYDRAULIC VALVE "PB" PORT		
		29913	FITTING, #10 ORB X #8 JIC STR.	1
		8M3K 8G-8FJX 8G-8FJX90S 17	HYDRAULIC HOSE	1
		40320	FITTING, #6 ORB X #8 JIC STR.LONG	1
	8	FLOW CONTROL #2 PORT TO HYDRAULIC VALVE TANK PORT		
		29896	FITTING, #8 ORB X #8 JIC STR.	1
		8M3K 8G-8FJX 8G-8FJX 44	HYDRAULIC HOSE	1
		29976	FITTING, #8 ORB BRANCH TEE	1
	9	HYDRAULIC VALVE TANK PORT TO HYDRAULIC OIL COOLER		
		29976	FITTING, #8 ORB BRANCH TEE	1
		8M3K 8G-8FJX90S 8G-10FJX 27	HYDRAULIC HOSE	1
		29805	FITTING, #10 JIC BULKHEAD	1
		29807	NUT, BULKHEAD FITTING	1
		46432	TUBE, HYDRAULIC RETURN	1
		29805	FITTING, #10 JIC BULKHEAD	1
		29807	NUT, BULKHEAD FITTING	1
		12M3K 12G-10FJX 12G-16FJX 29	HYDRAULIC HOSE	1
		29951	FITTING, #16 ORB X #16 JIC STR.	1
	10	HYDRAULIC PUMP PRESS. (REAR PORT) TO HYDRAULIC VALVE "P" PORT		
		29842	FITTING, #12 ORB X #10 JIC 90°	1
		10M3K 19G-10FJX 10G-10FJX 25	HYDRAULIC HOSE	1
		29805	FITTING, #10 JIC BULKHEAD	1
		29807	NUT, BULKHEAD FITTING	1
		46435	TUBE, HYDRAULIC RETURN	1
		29805	FITTING, #10 JIC BULKHEAD	1
		29807	NUT, BULKHEAD FITTING	1
		10M3K 19G-10FJX 10G-10FJX 25	HYDRAULIC HOSE	1
		29908	FITTING, #8 ORB X #8 JIC 90°	1

Chapter 8 Illustrated Parts List

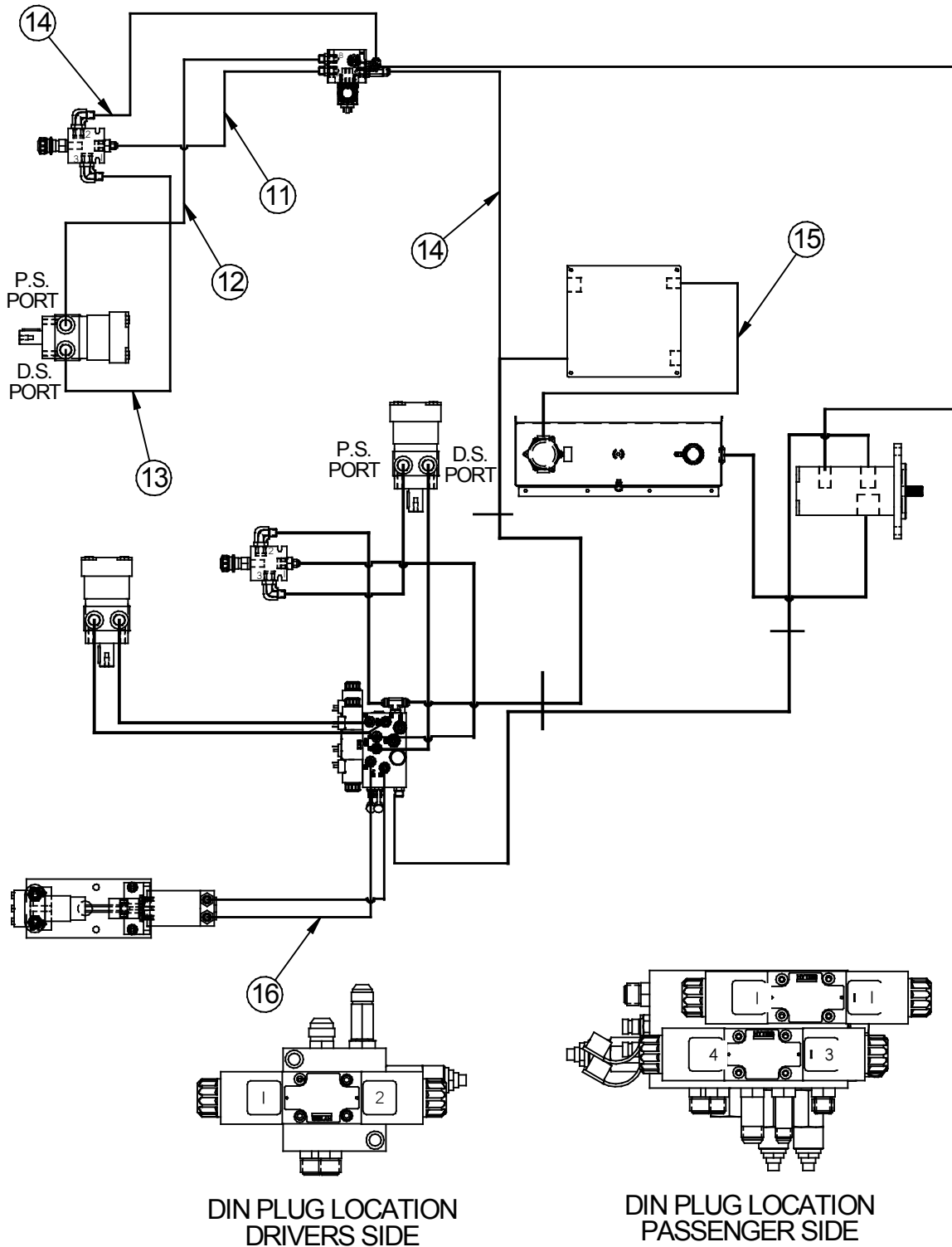

Fig. 9.22 Hydraulic Diagram

Chapter 8 Illustrated Parts List

FIG.	ITEM	PART NO.	DESCRIPTION	QTY.
Fig. 9.22	11	HYDRAULIC VALVE "A" PORT TO FLOW CONTROL #1 PORT		
		29897	FITTING, #8 ORB X #8 JIC STR.	1
		8M3K 8G-8FJX 8G-8FJX 23	HYDRAULIC HOSE	1
		29896	FITTING, #8 ORB X #8 JIC 90°	1
	12	FLOW CONTROL #3 PORT TO PUMP MOTOR PASS. SIDE PORT		
		29896	FITTING, #8 ORB X #8 JIC 90°	1
		8M3K 8G-8FJX90S 8G-8FJX 25	HYDRAULIC HOSE	1
		29913	FITTING, #10 ORB X #8 JIC STR.	1
	13	PUMP MOTOR DRIVERS SIDE PORT TO HYDRAULIC VALVE "B" PORT		
		29913	FITTING, #10 ORB X #8 JIC STR.	1
		8M3K 8G-8FJX90S 8G-8FJX 20	HYDRAULIC HOSE	1
		29897	FITTING, #8 ORB X #8 JIC STR.	1
	14	FLOW CONTROL #2 PORT TO HYDRAULIC OIL COOLER		
		29896	FITTING, #8 ORB X #8 JIC 90°	1
		8M3K 8G-8FJX 8G-8FJX 44	HYDRAULIC HOSE	1
		29932	FITTING, #12 ORB RUN TEE	1
		8M3K 8G-8FJX 8G-10FJX 21	HYDRAULIC HOSE	1
		29805	FITTING, #10 JIC BULKHEAD	1
		29807	NUT, BULKHEAD FITTING	1
		46436	TUBE, HYDRAULIC RETURN	1
		29805	FITTING, #10 JIC BULKHEAD	1
		29807	NUT, BULKHEAD FITTING	1
		12M3K 12G-10FJX 12G-16FJX90S 26	HYDRAULIC HOSE	1
		29951	FITTING, #16 ORB X #16 JIC STR.	1
	15	HYDRAULIC OIL COOLER TO HYDRAULIC OIL TANK		
		29820	FITTING, #16 ORB X #16 JIC STR.	1
		16M3K 16G-16FJX90S 16G-16FJX 37	HYDRAULIC HOSE	1
		29818	FITTING, #20 ORB X #16 JIC STR.	1
	16	HYDRAULIC VALVE (HA PORT) TO HYDRAULIC OIL PUMP		
	29919	FITTING, #6 ORB X #8 JIC	1	
	6M3K 6G-6FJX 6G-6FJX90S 20	HYDRAULIC HOSE	1	
	22029	FITTING, #10 ORB X #6 JIC	1	

Chapter 8 Illustrated Parts List

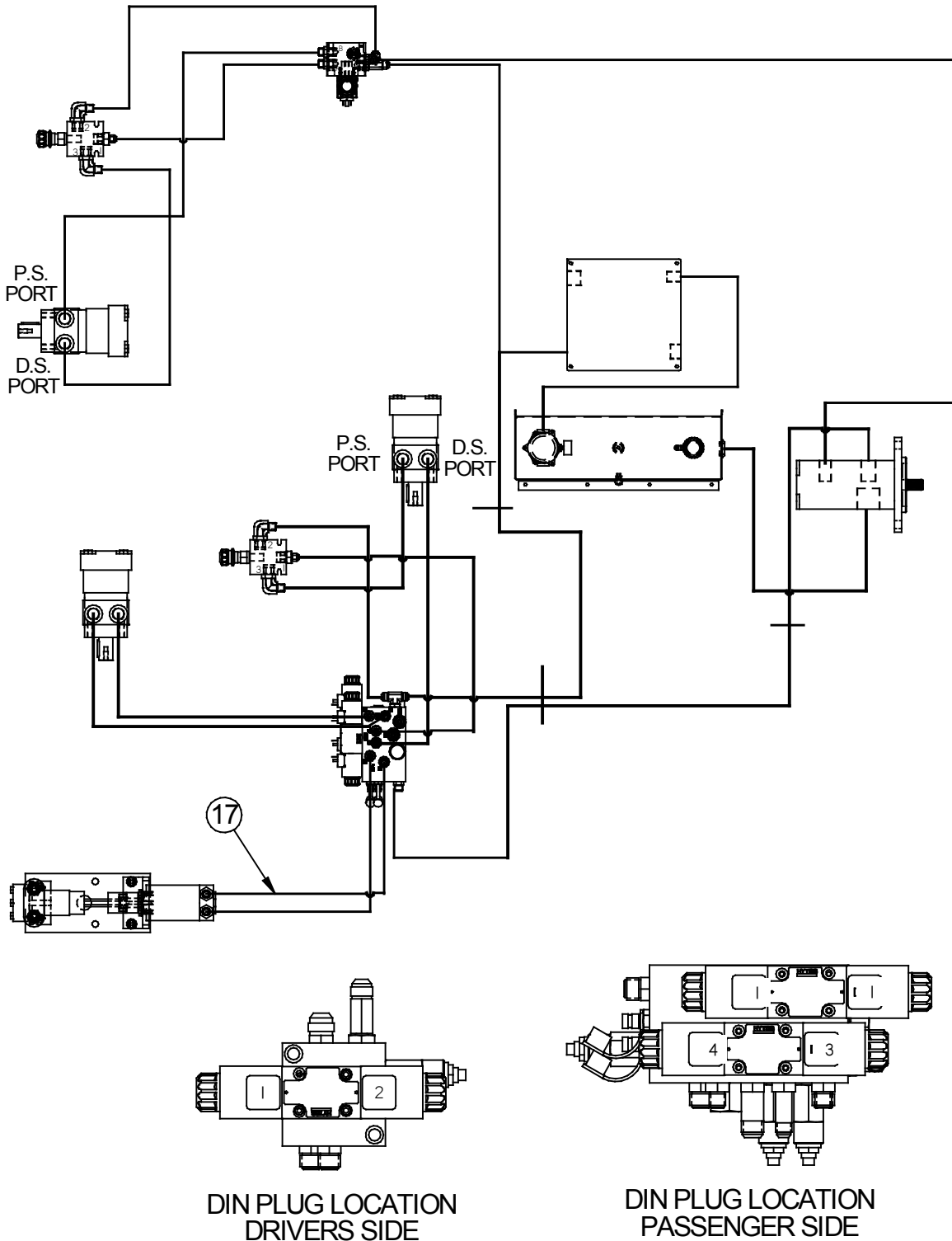

Fig. 9.23 Hydraulic Diagram

+

Chapter 8 Illustrated Parts List

FIG.	ITEM	PART NO.	DESCRIPTION	QTY.
Fig. 9.23	17	HYDRAULIC OIL PUMP TO HYDRAULIC VALVE (HB PORT)		
		22029	FITTING, #10 ORB X #6 JIC	1
		6M3K 6G-6FJX 6G-8FJX90S 22	HYDRAULIC HOSE	1
		40311	FITTING, #6 ORB X #6 JIC STR.	1

Chapter 8 Illustrated Parts List

9.18 Electrical Schematic – Electric Hose

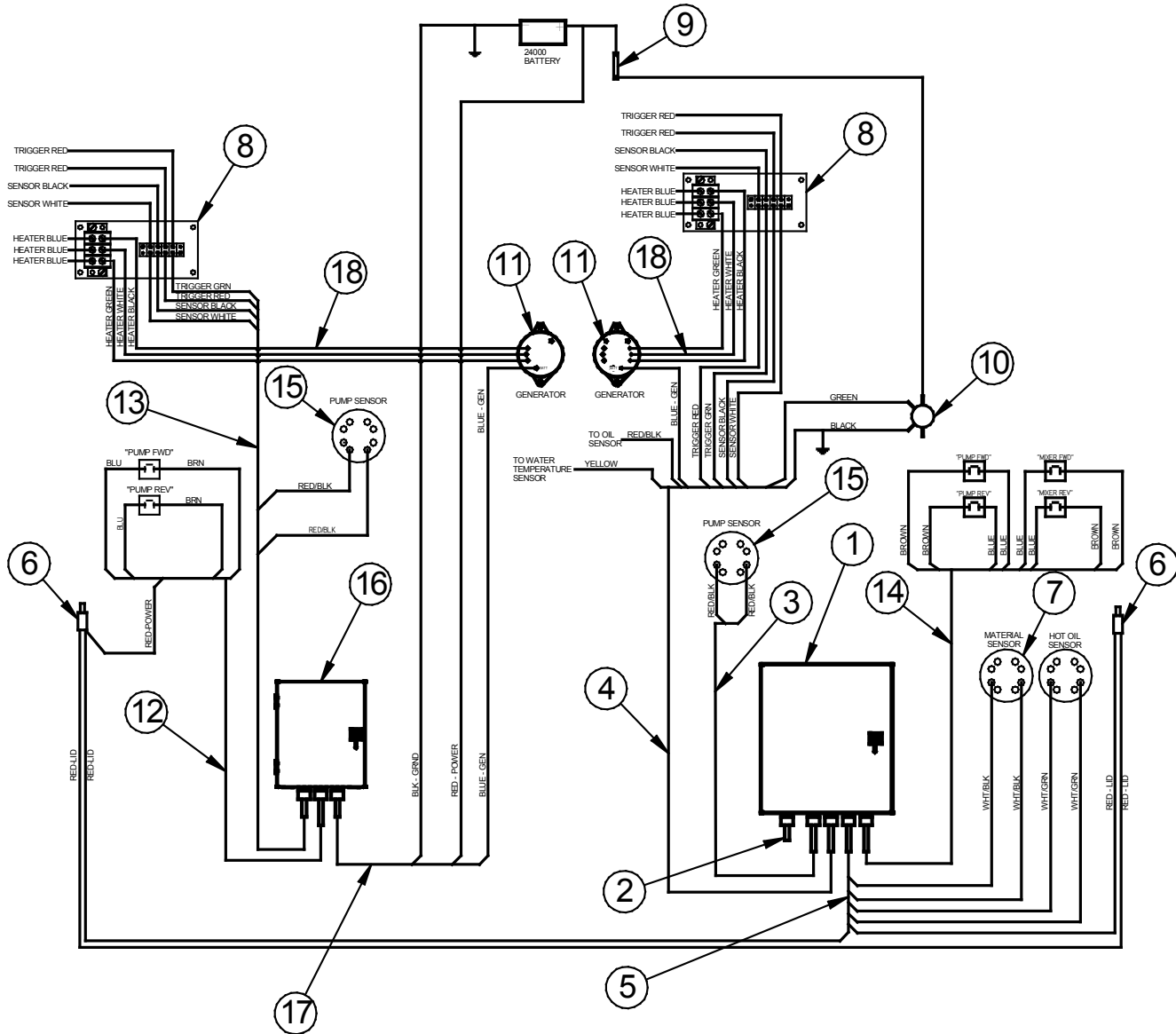

Fig. 9.24 Electrical Schematic 46500EB

Chapter 8 Illustrated Parts List

FIG.	ITEM	PART NO.	DESCRIPTION	QTY.
Fig. 9.24	1	46620	CONTROL BOX ASSEMBLY, P.S.	1
	2	44978	WIRING HARNESS, ENGINE	1
	3	51836	CABLE ASSEMBLY, TRIGGER – P.S.	1
	4	51835	CABLE ASSEMBLY, ENGINE – P.S.	1
	5	51834	CABLE ASSEMBLY, SENSOR – P.S.	1
	6	39608	LID SWITCH	2
	7	43465	SENSOR, RTD	2
	8	44027	JUNCTION BOX, HOSE	2
	9	31512	CIRCUIT BREAKER	1
	10	39602	SOLENOID, FRAME	1
	11	46322	GENERATOR	2
	12	43937	CABLE ASSEMBLY, VALVE – D.S.	1
	13	43974	CABLE ASSEMBLY, SENSOR – D.S.	1
	14	43984	CABLE ASSEMBLY, VALVE – P.S.	1
	15	56940	SENSOR, RTD – PUMPING TEMPERATURE	2
	16	46710	CONTROL BOX ASSEMBLY, D.S.	1
	17	43981	CABLE ASSEMBLY, TRIGGER – D.S.	1
	18	43947	CABLE ASSEMBLY, HOSE	2

Chapter 8 Illustrated Parts List

9.19 Electrical Schematic – Standard Hose

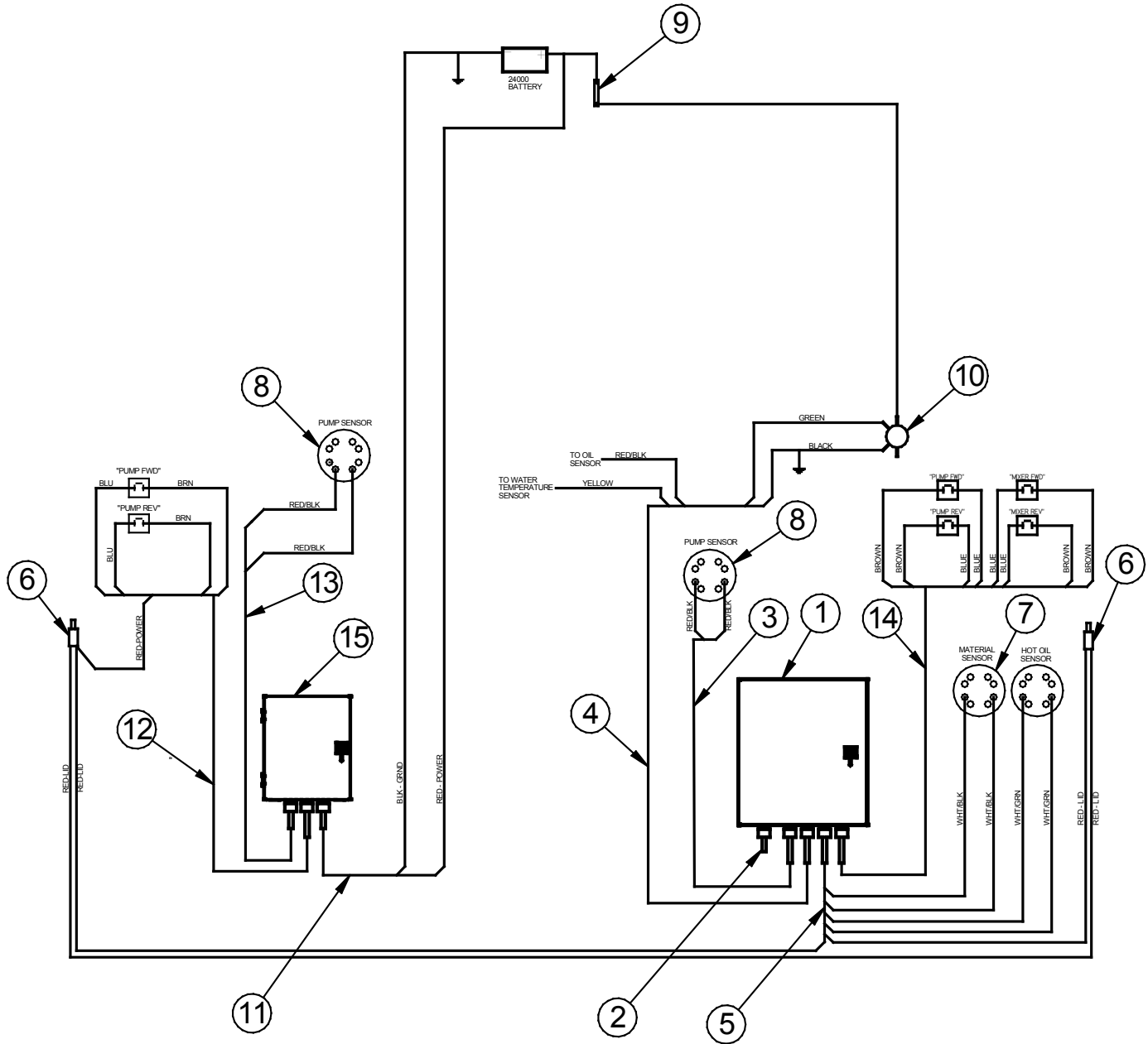

Fig. 9.25 Electric Schematic – 4650SB

Chapter 8 Illustrated Parts List

FIG.	ITEM	PART NO.	DESCRIPTION	QTY.
Fig. 9.25	1	46715	CONTROL BOX ASSEMBLY, P.S.	1
	2	44978	WIRING HARNESS, ENGINE	1
	3	51836	CABLE ASSEMBLY, TRIGGER – P.S.	1
	4	51835	CABLE ASSEMBLY, ENGINE – P.S.	1
	5	51834	CABLE ASSEMBLY, SENSOR – P.S.	1
	6	39608	LID SWITCH	2
	7	43465	SENSOR, RTD	2
	8	55120	SENSOR, RTD – PUMPING TEMPERATURE	2
	9	31512	CIRCUIT BREAKER	1
	10	39602	SOLENOID, FRAME	1
	11	43981	CABLE ASSEMBLY, TRIGGER – D.S.	1
	12	43937	CABLE ASSEMBLY, VALVE – D.S.	1
	13	51819	CABLE ASSEMBLY, SENSOR – D.S.	1
	14	43984	CABLE ASSEMBLY, VALVE – P.S.	1
	15	46720	CONTROL BOX ASSEMBLY, D.S.	1

Chapter 8 Illustrated Parts List

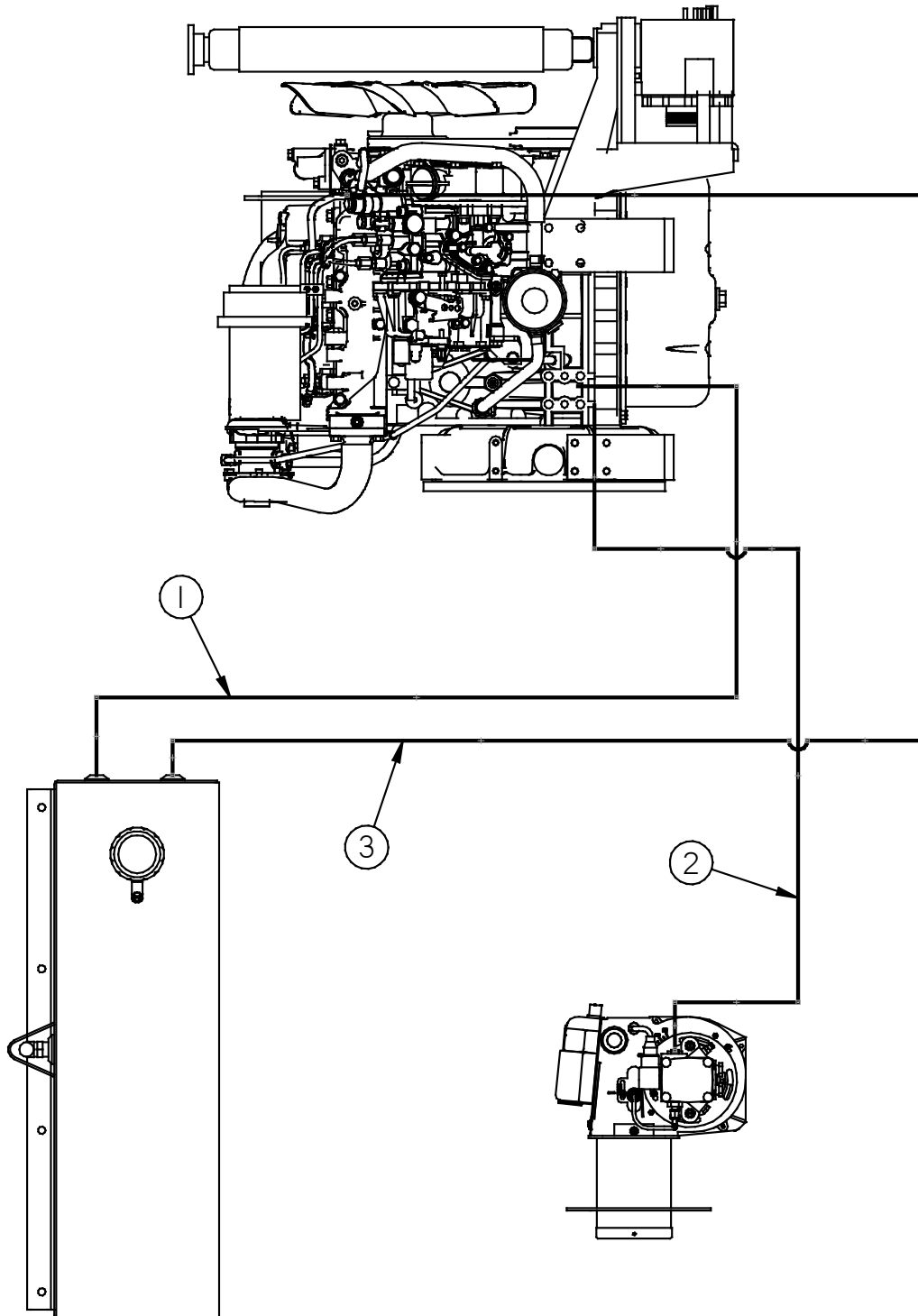

Fig. 9.26 Diesel Fuel Line Schematic

Chapter 8 Illustrated Parts List

FIG.	ITEM	PART NO.	DESCRIPTION	QTY.
Fig. 9.26	1. DIESEL FUEL TANK TO ENGINE FUEL FILTER "IN" PORT			
	1	26782	FITTING, 1/4 MPT X 5/16 JIC ELBOW	1
	1	26767	FITTING, #5 HOSE PUSH-ON	1
	1	29591	HOSE, 5/16 FUEL LINE	1
	2	26080	CLAMP, #4 GEAR	2
	1	-	BANJO FITTING	REF.
	2. ENGINE FUEL FILTER UPPER FITTING TO BURNER			
	1	-	BANJO FITTING	REF.
	1	29591	HOSE, 5/16 FUEL LINE	1
	1	26767	FITTING, #5 HOSE PUSH-ON	1
	1	26782	FITTING, 1/4 MPT X 5/16 JIC ELBOW	1
	2	26080	CLAMP, #4 GEAR	2
	3. ENGINE RETURN LINE TO DIESEL FUEL TANK			
	1	29591	HOSE, 5/16 FUEL LINE	1
	1	26767	FITTING, #5 HOSE PUSH-ON	1
	1	26782	FITTING, 1/4 MPT X 5/16 JIC ELBOW	1
	2	26080	CLAMP, #4 GEAR	2

Chapter 8 Illustrated Parts List

9.20 Hot Air Lance

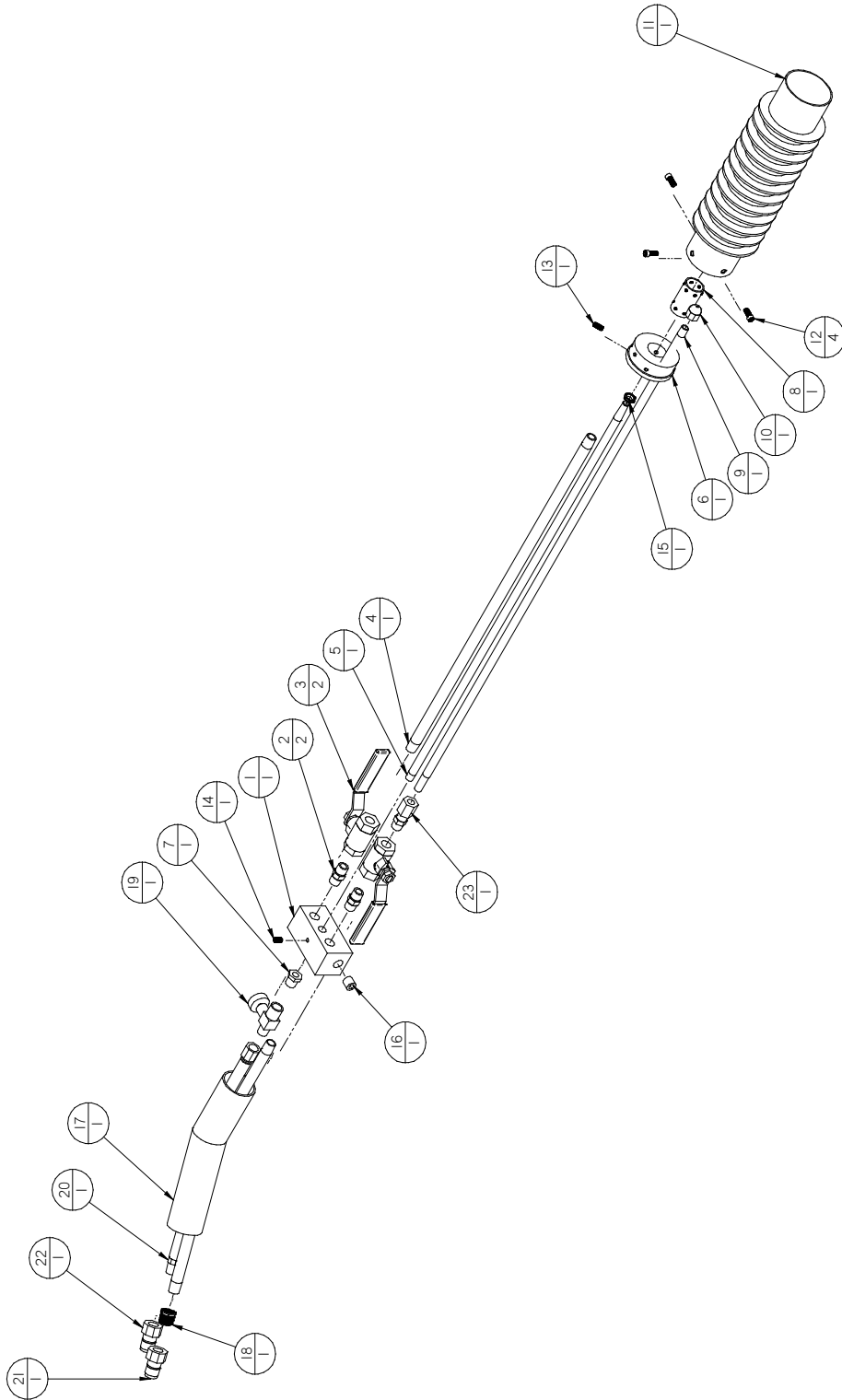

Fig. 9.27 Hot Air Lance (Option)

Chapter 8 Illustrated Parts List

FIG.	ITEM	PART NO.	DESCRIPTION	QTY.
Fig. 9.27	1	45651	MIXING BLOCK	1
	2	51401	NIPPLE, 1/4 NPT HEX	2
	3	29195	VALVE, 1/4" BALL	2
	4	45656	AIR MIXER TUBE	1
	5	45658	PROPANE TUBE W/ ORFICE	1
	6	45652	BURNER BASE	1
	7	28340	BUSHING, 1/4" NPT X 1/8" NPT	1
	8	45654	PRIMARY BURNER TUBE	1
	9	45657	AIR LANCE TUBE	1
	10	45668	AIR ORFICE "A" - .125"	1
	11	45653	MAIN BURNER TUBE	1
	12	45670	SCREW, #10-32 X 1/2" ALLEN SCREW	4
	13	45672	SCREW, #10-32 X 1/2" ALLEN SET	1
	14	45671	SCREW, 1/4-20 X 3/8" ALLEN SET	1
	15	45669	NUT, 1/8-27 JAM	1
	16	27990	PLUG, 1/4" COUNTERSUNK	1
	17	45655	HANDLE ASSEMBLY	1
	18	45663	BUSHING, 3/8" NPT X 1/4" NPT REDUCER	1
	19	45659	VALVE, NEEDLE	1
	20	45675	HOSE ASSEMBLY, PROPANE	1
	21	45679	COUPLING, 1/4" FPT X M	1
	22	45681	COUPLING, 1/4" NPT X FM	1
	23	45664	FITTING, 1/4" NPT X 3/8 JIC FERRULE LOCK	1

Chapter 9 Tools and Accessories

10.0 Tools and Accessories



Crafcoco Applicator Disk
27162 – 3" Disk Assembly
27163 – 4" Disk Assembly
27164 – 6" Disk Assembly



Crafcoco Swivel Disk Applicator
27120 – 3" Swivel Applicator
27130 – 4" Swivel Applicator



Crafcoco Sealing Foot/Flush
27154 – 1/4" Flush
27155 – 3/8" Flush



Crafcoco Sealing Foot/Protruded
27159 – 1/4" Protruding
27160 – 3/8" Protruding



Crafcoco Joint Sealing Tip
27146 – 1/4" Sealing Tip
27147 – 3/8" Sealing Tip



Crafcoco Round Sealing Tip
27170 – 3/8" Sealing Tip
27171 – 1/2" Sealing Tip



Crafcoco Cold Air Lance - 42648

Chapter 9 Tools and Accessories



Crafco Heavy Duty Squeegee with Aluminum Handle - 27199
27195 – Replacement Blade



Crafco Pour Pot with Wheels - 40200



Super Shot Drip Stopper
Use with 50270 Duckbill
27114 – Tip Adapter
27115 – Shroud, Tip Adapter



Crafco Hand Held Pour Pot - 40201



Crafco Duckbill - 50270



Crafco Heat Lance - 31370

Chapter 9 Tools and Accessories



Crafco Heat Lance with Regulator and Attachments - 32259



Crafco Hand Torch w/ 20ft. Hose - 25012



©2015 Crafco, Inc.